

**STAIR SPECIFICATIONS**  
 ALUMINUM CONSTRUCTION  
 HANDRAILS TO BE SAFETY YELLOW  
 COMPLIANT WITH OSHA 1910.25 FIXED STAIR STANDARDS  
 -30 TO 50 DEGREES  
 -UNIFORM RISER HEIGHT, MAX 9.5"  
 -UNIFORM TREAD DEPTH, MIN 9.5"  
 -MIN 26" WIDTH  
 -TREADS SUPPORT 5X THE ANTICIPATED LIVE LOAD,  
 NEVER LESS THAT A CONCENTRATED LOAD OF 1000LBS  
 AT ANY GIVEN POINT  
 -PLATFORMS AND LANDINGS - MIN OF 30"X30"  
 -ALL OTHER 1910.25 SPECIFICATIONS

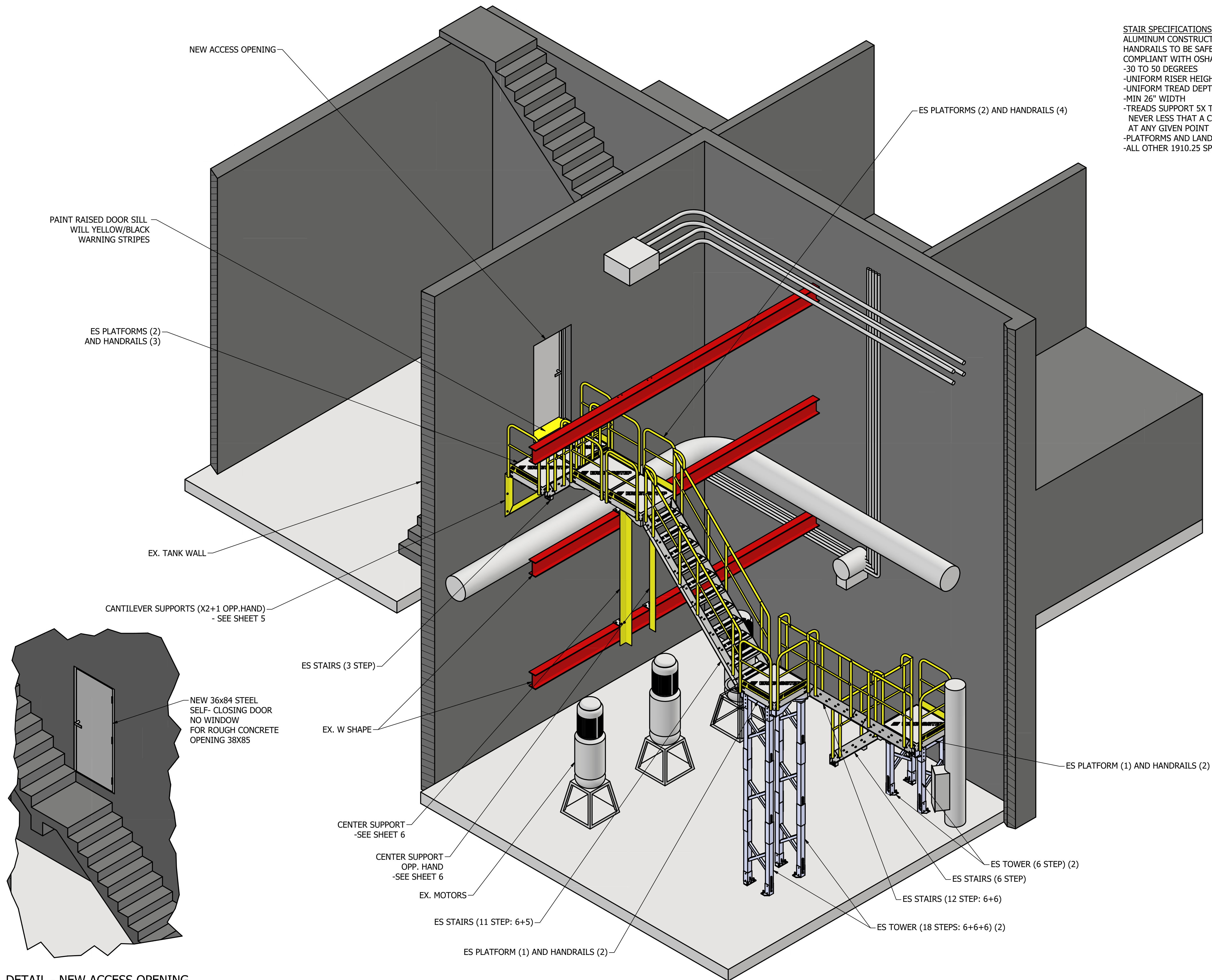

DETAIL - NEW ACCESS OPENING

**REVISIONS:**

REV	REVISION ISSUE	DATE
A	ISSUED FOR APPROVAL	04/24/23
B	ISSUED FOR APPROVAL	06/30/23
C	ISSUED FOR APPROVAL	09/11/24
0	ISSUED FOR CONSTRUCTION	09/11/24

**SHEET DESCRIPTION:**

NEW STAIR ISOMETRIC VIEW

**SHEET 1 OF 12**

THIS DRAWING IS THE PROPERTY OF INDUSTRIAL TURNAROUND CORPORATION AND IS SUPPLIED FOR USE ONLY FOR AN AUTHORIZED PROJECT. THIS DRAWING CONTAINS CONFIDENTIAL AND PROPRIETARY INFORMATION OF INDUSTRIAL TURNAROUND CORPORATION AND SHALL NOT BE DISCLOSED, USED, COPIED OR REPRODUCED EITHER WHOLLY OR IN PART, EXCEPT IN CONNECTION WITH SUCH USE AND WITH THE PRIOR WRITTEN CONSENT OF INDUSTRIAL TURNAROUND CORPORATION. THIS DRAWING MUST NOT BE USED FOR CONSTRUCTION OR FABRICATION UNTIL SIGNED AS CHECKED AND ISSUED FOR CONSTRUCTION.

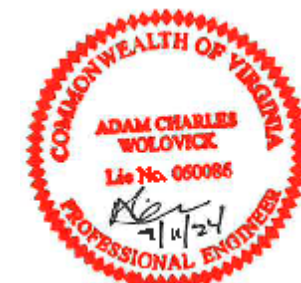

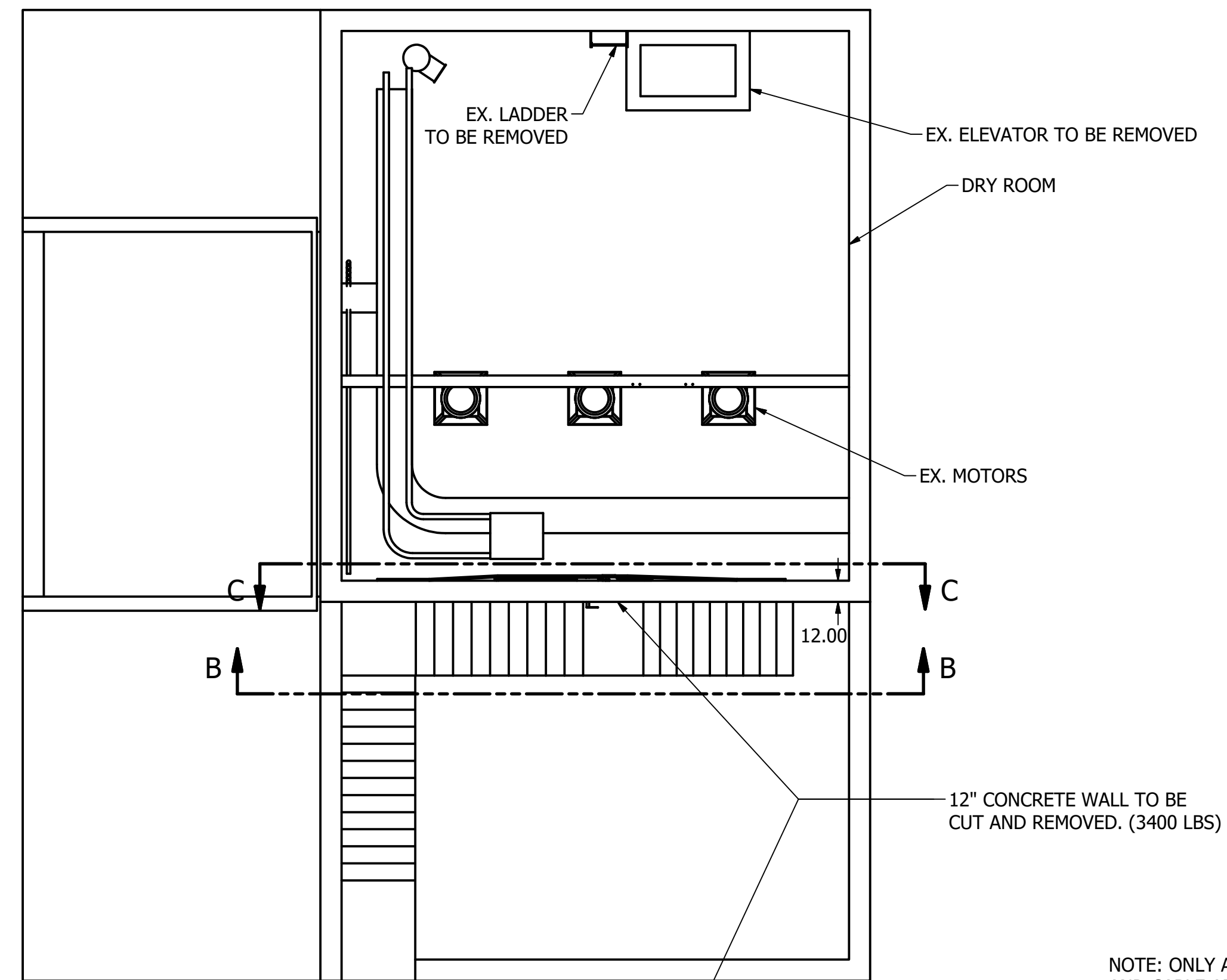

EX. TANK PLAN

NOTE: ONLY AFFECTED CONDUITS AND CABLE ARE SHOWN IN THIS VIEW  
 RECOMMEND EXPLORATORY DRILLING TO VERIFY EXACT HOLE PLACEMENT.

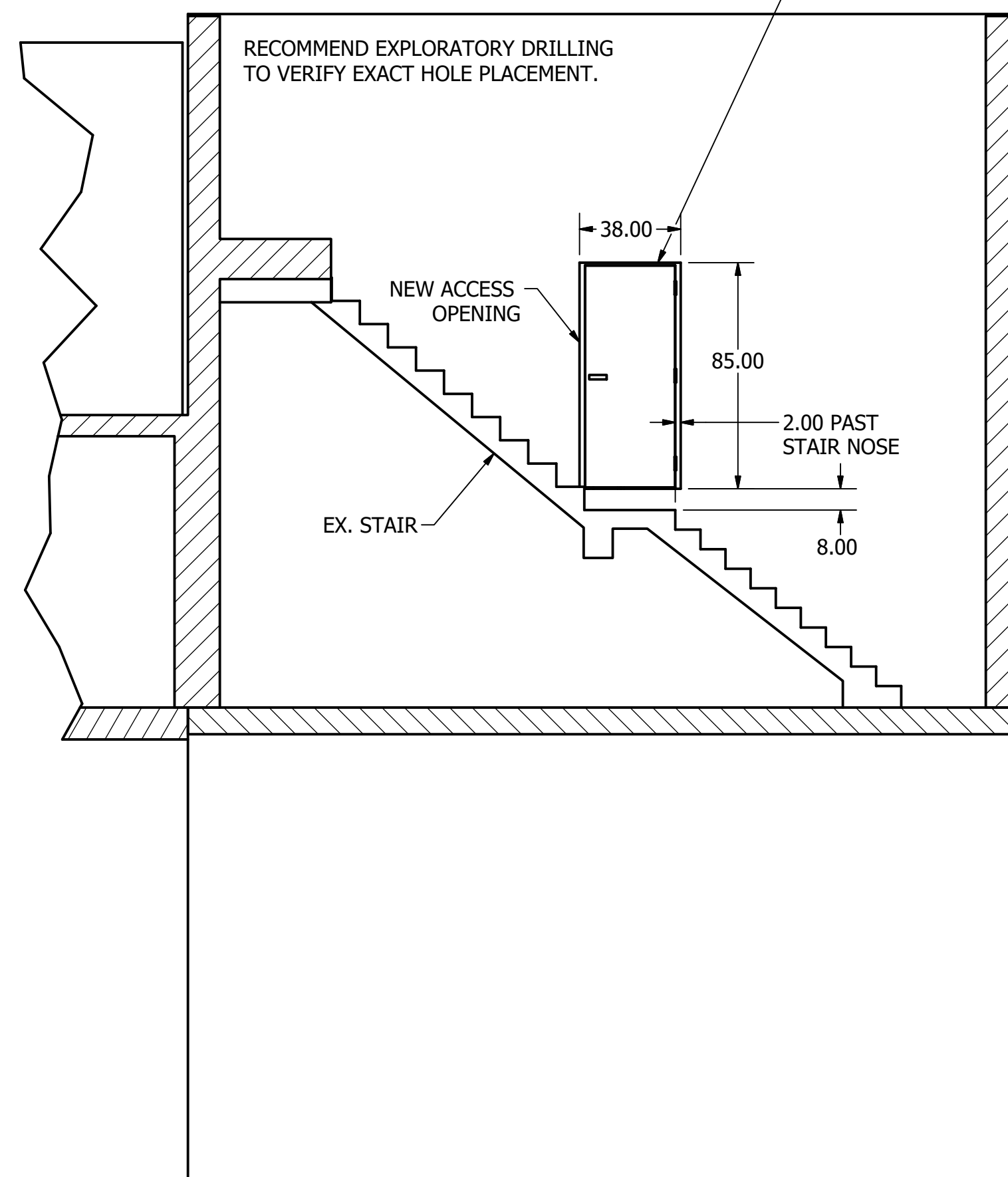

SECTION B-B  
 SCALE 1"=4'-0"

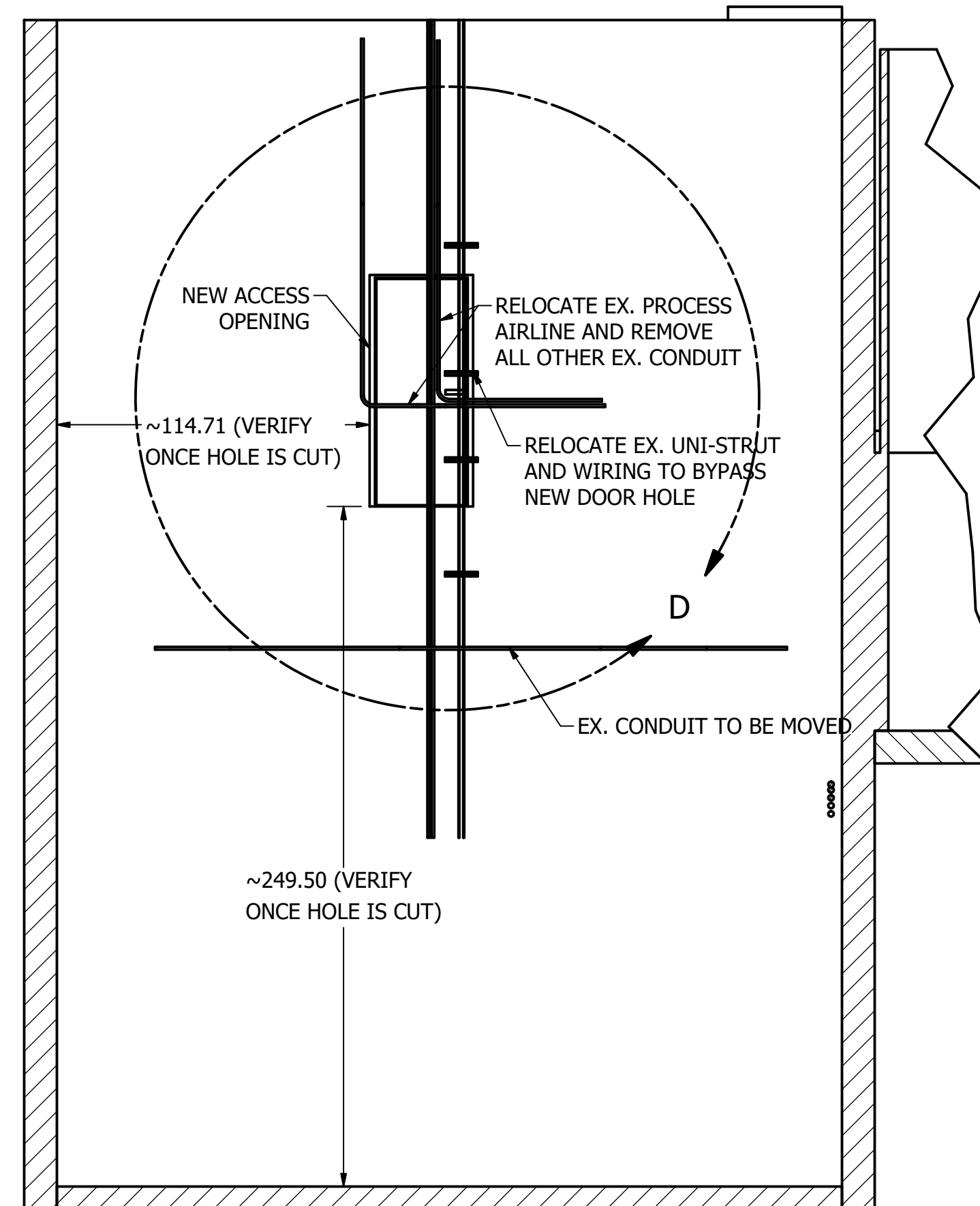

SECTION C-C  
 SCALE 1"=4'-0"

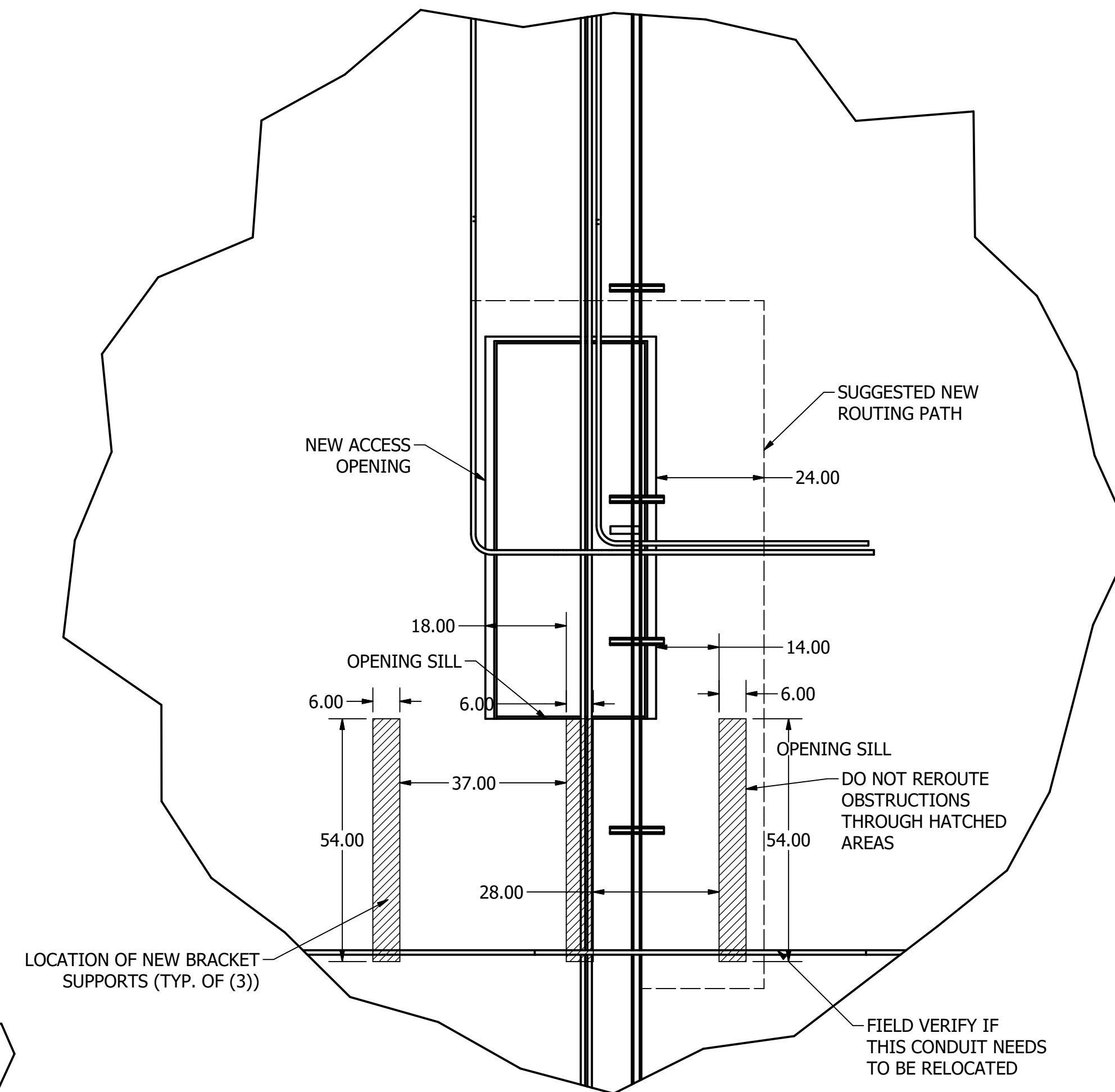

DETAIL D  
 SCALE 1"=2'-0"

**REVISIONS:**

REV	REVISION ISSUE	DATE
A	ISSUED FOR APPROVAL	04/24/23
B	ISSUED FOR APPROVAL	06/30/23
C	ISSUED FOR APPROVAL	09/11/24
0	ISSUED FOR CONSTRUCTION	09/11/24

**SHEET DESCRIPTION:**

SITE PREPARATION PLAN

**SHEET 2 OF 12**

THIS DRAWING IS THE PROPERTY OF INDUSTRIAL TURNAROUND CORPORATION AND IS SUPPLIED FOR USE ONLY FOR AN AUTHORIZED PROJECT. THIS DRAWING CONTAINS CONFIDENTIAL AND PROPRIETARY INFORMATION OF INDUSTRIAL TURNAROUND CORPORATION AND SHALL NOT BE DISCLOSED, USED, COPIED OR REPRODUCED EITHER WHOLLY OR IN PART, EXCEPT IN CONNECTION WITH SUCH USE AND WITH THE PRIOR WRITTEN CONSENT OF INDUSTRIAL TURNAROUND CORPORATION. THIS DRAWING MUST NOT BE USED FOR CONSTRUCTION OR FABRICATION UNTIL SIGNED AS CHECKED AND ISSUED FOR CONSTRUCTION.

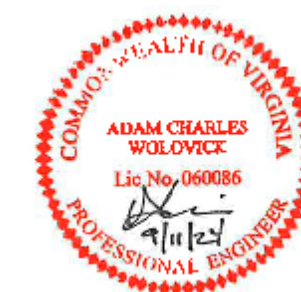

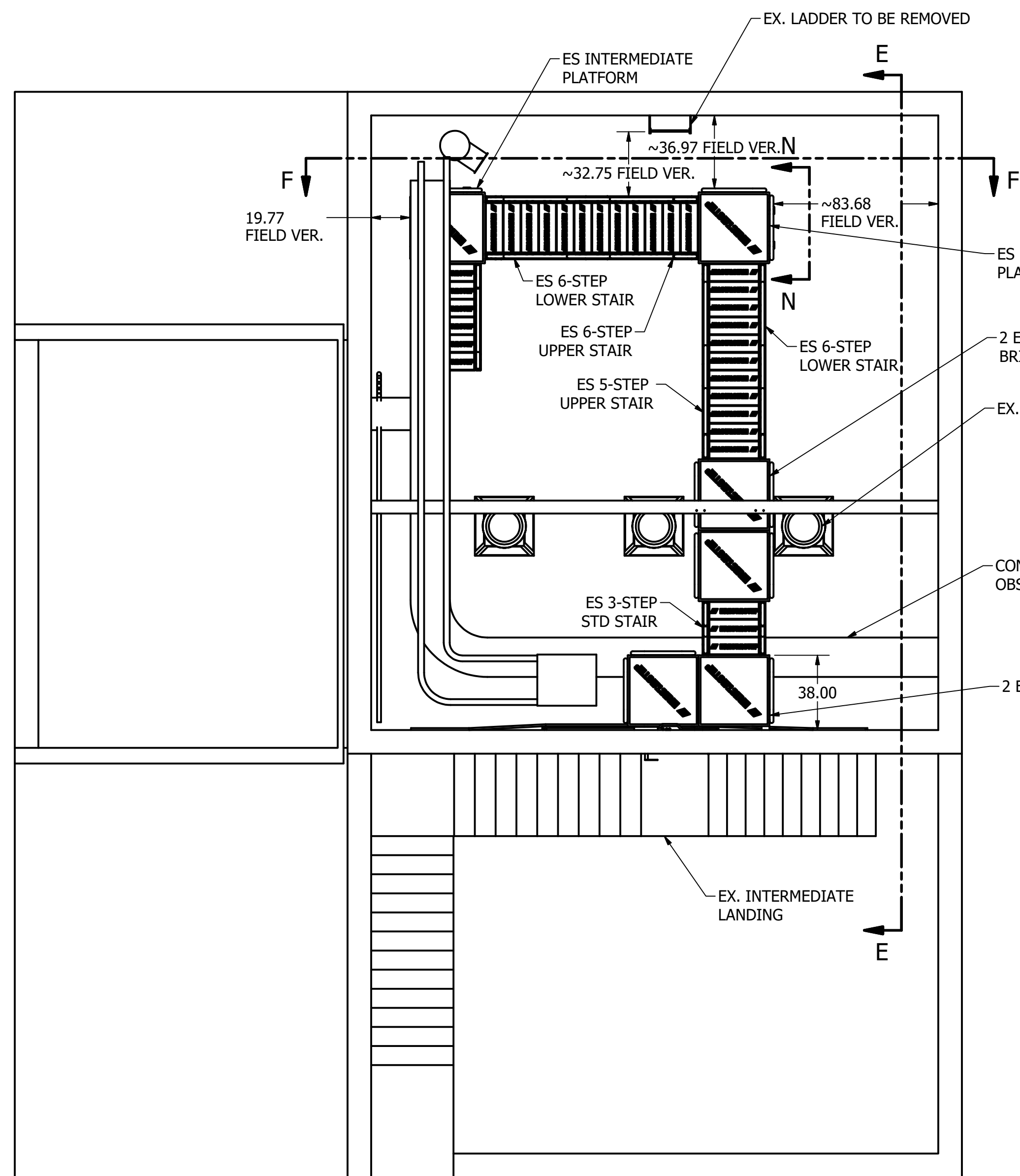

**NEW STAIR PLAN**

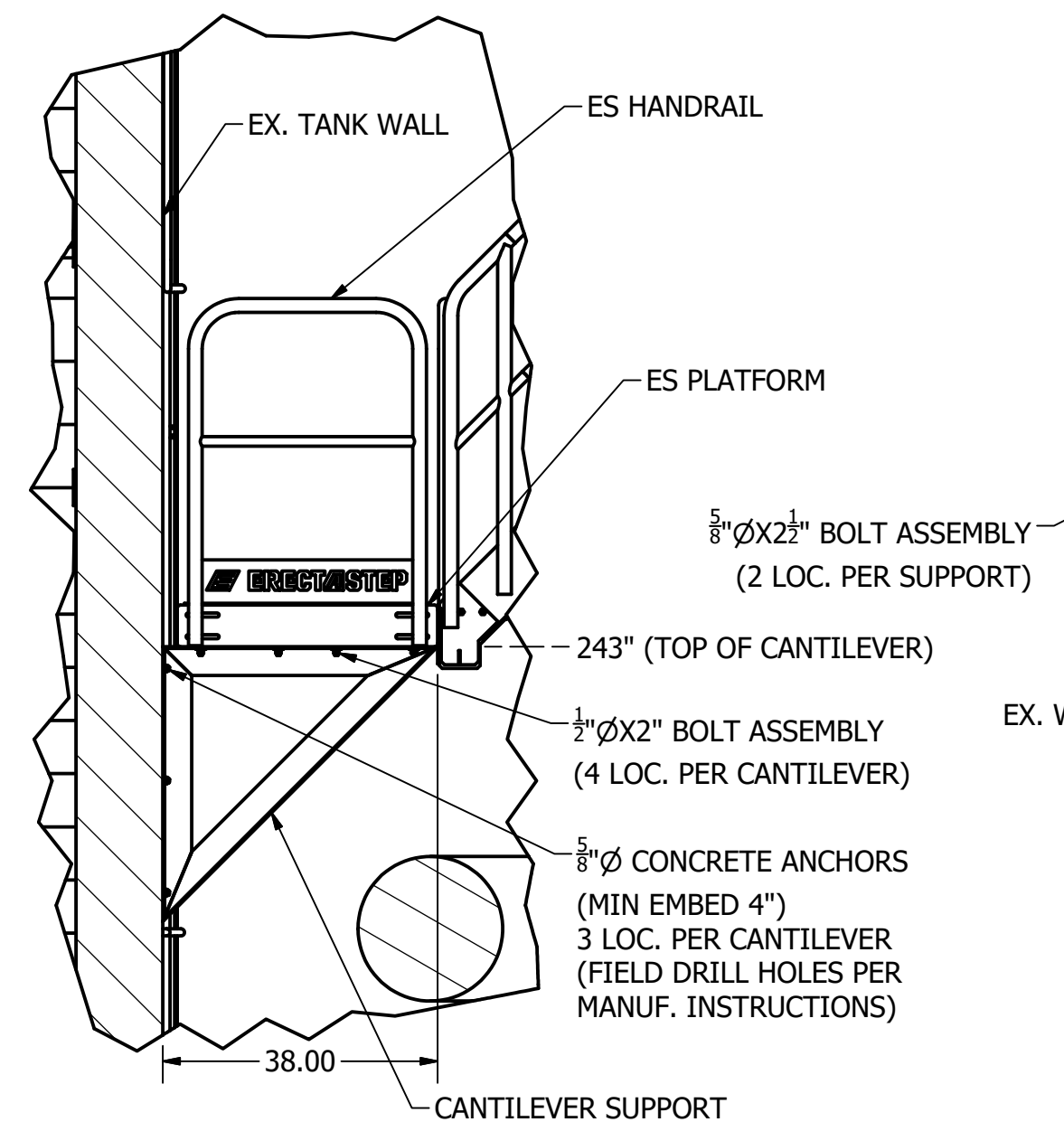

**DETAIL L**  
 SCALE 1"=2'-0"

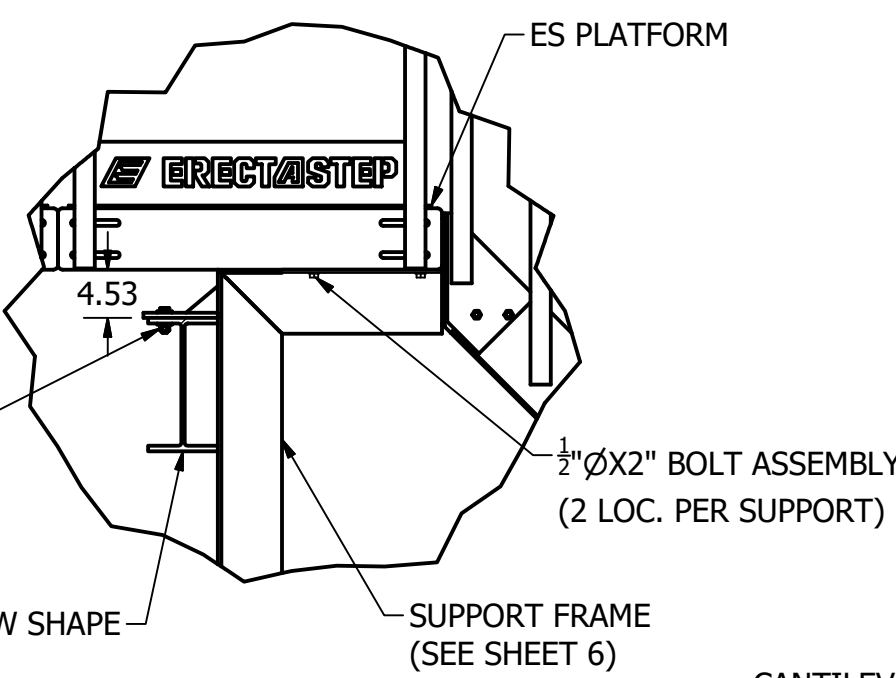

**DETAIL M**  
 SCALE 1"=1'-6"

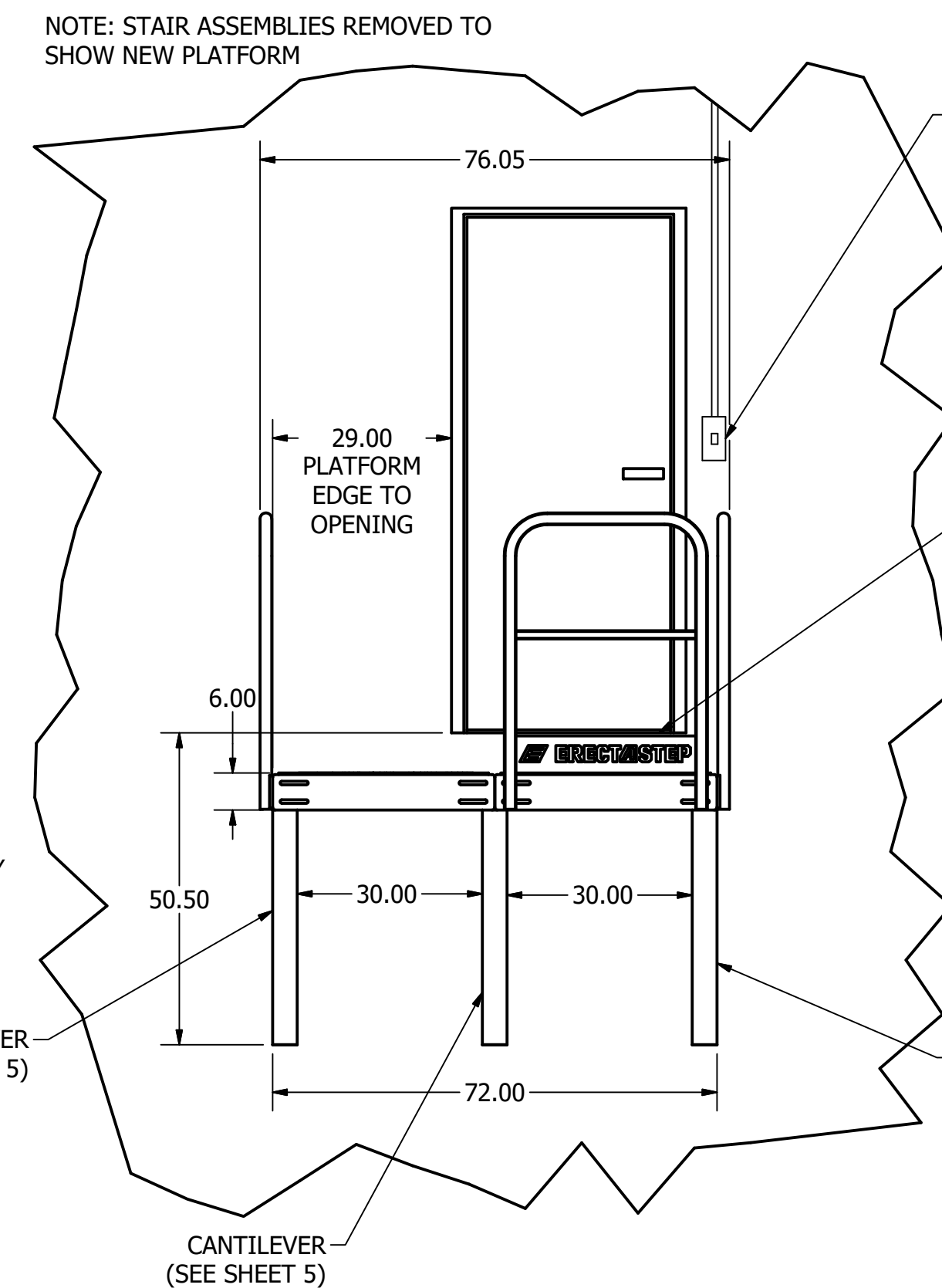

**DETAIL K**  
 SCALE 1"=2'-0"

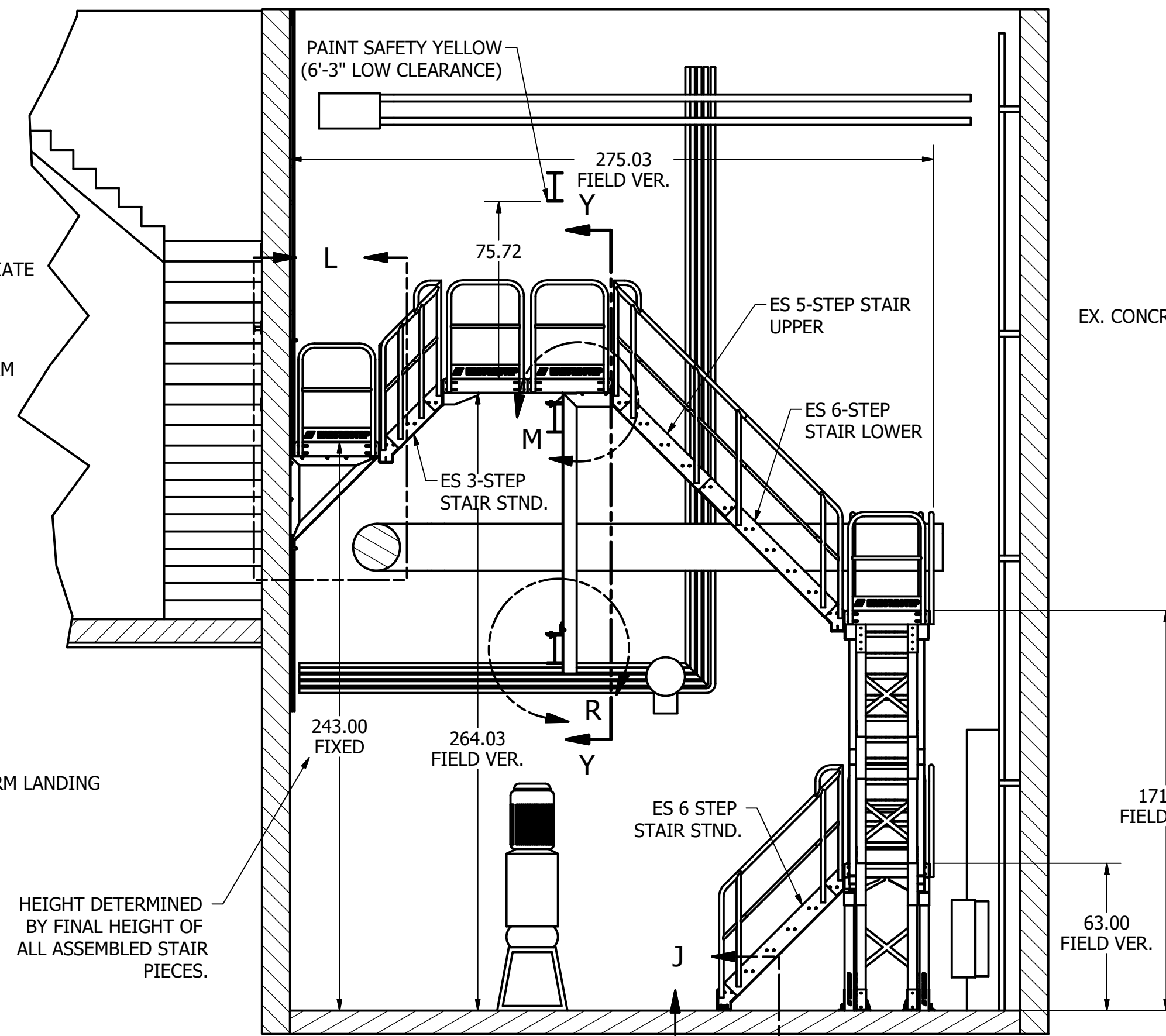

**SECTION E-E**  
 SCALE 1"=4'-0"

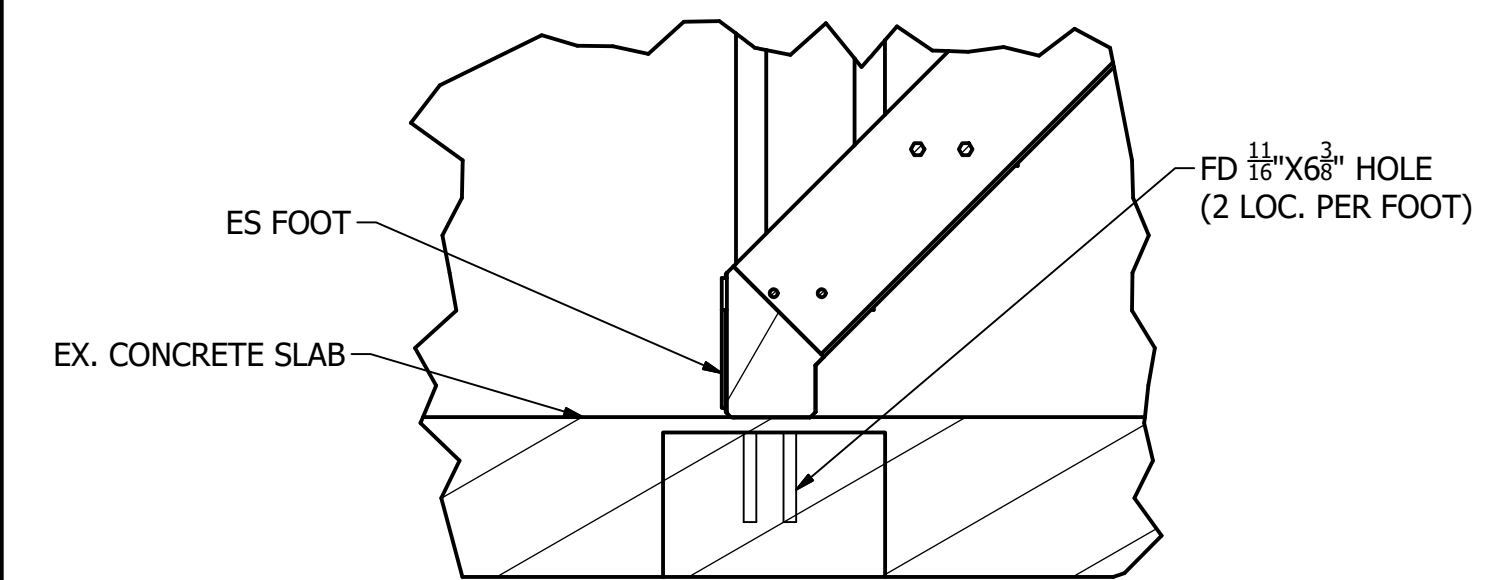

**DETAIL J**  
 SCALE 1 / 12

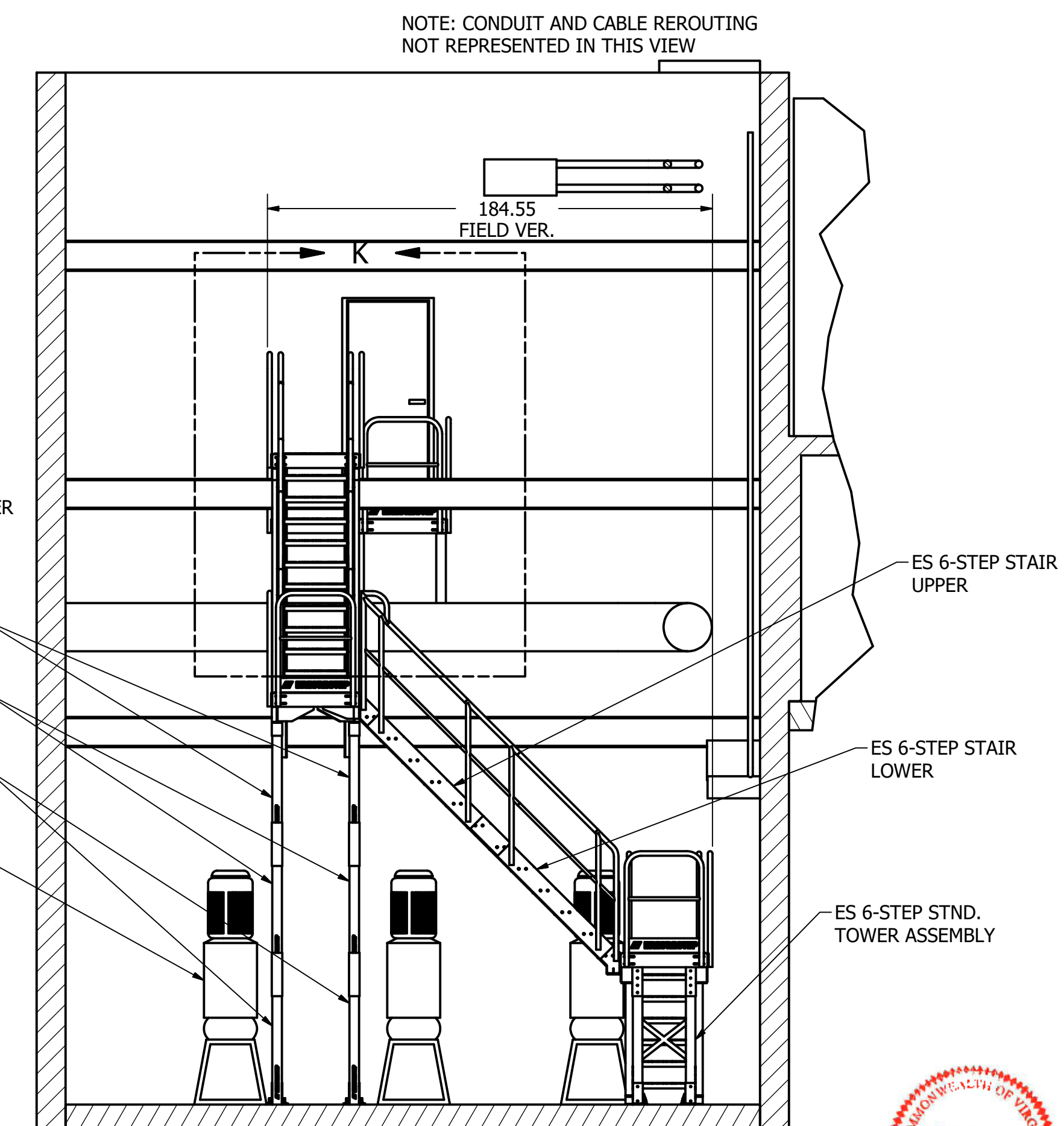

**SECTION F-F**  
 SCALE 1"=4'-0"

REVISIONS:		
REV	REVISION ISSUE	DATE
A	ISSUED FOR APPROVAL	04/24/23
B	ISSUED FOR APPROVAL	06/30/23
C	ISSUED FOR APPROVAL	09/11/24
D	ISSUED FOR CONSTRUCTION	09/11/24

**SHEET DESCRIPTION:**  
 PLAN AND DETAIL VIEWS

**SHEET 3 OF 12**

THIS DRAWING IS THE PROPERTY OF INDUSTRIAL TURNAROUND CORPORATION AND IS SUPPLIED FOR USE ONLY FOR AN AUTHORIZED PROJECT. THIS DRAWING CONTAINS CONFIDENTIAL AND PROPRIETARY INFORMATION OF INDUSTRIAL TURNAROUND CORPORATION AND SHALL NOT BE DISCLOSED, USED, COPIED OR REPRODUCED EITHER WHOLLY OR IN PART, EXCEPT IN CONNECTION WITH SUCH USE AND WITH THE PRIOR WRITTEN CONSENT OF INDUSTRIAL TURNAROUND CORPORATION. THIS DRAWING MUST NOT BE USED FOR CONSTRUCTION OR FABRICATION UNTIL SIGNED AS CHECKED AND ISSUED FOR CONSTRUCTION.

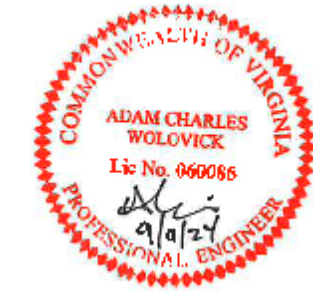

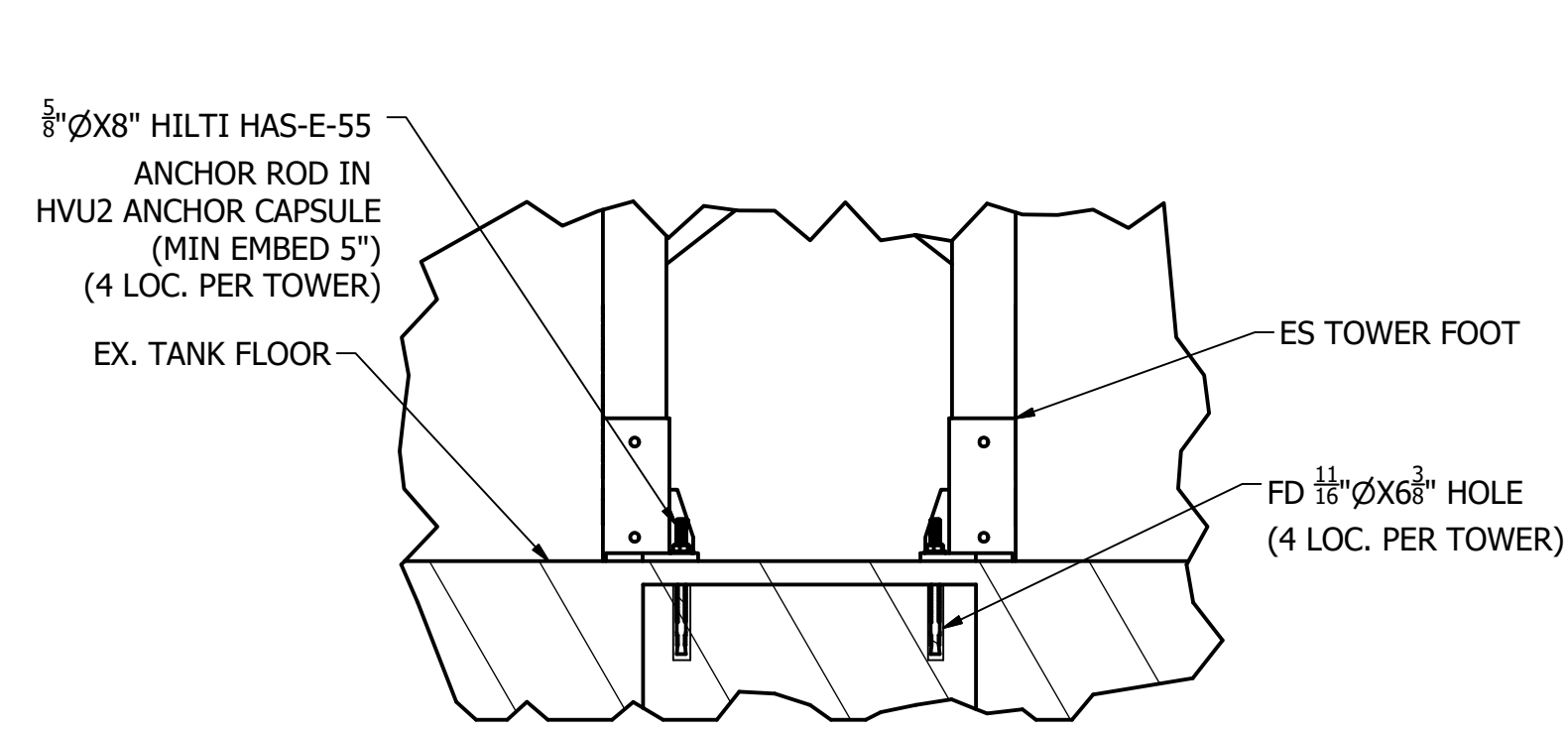

**DETAIL P**  
 SCALE 1"=1'-0"

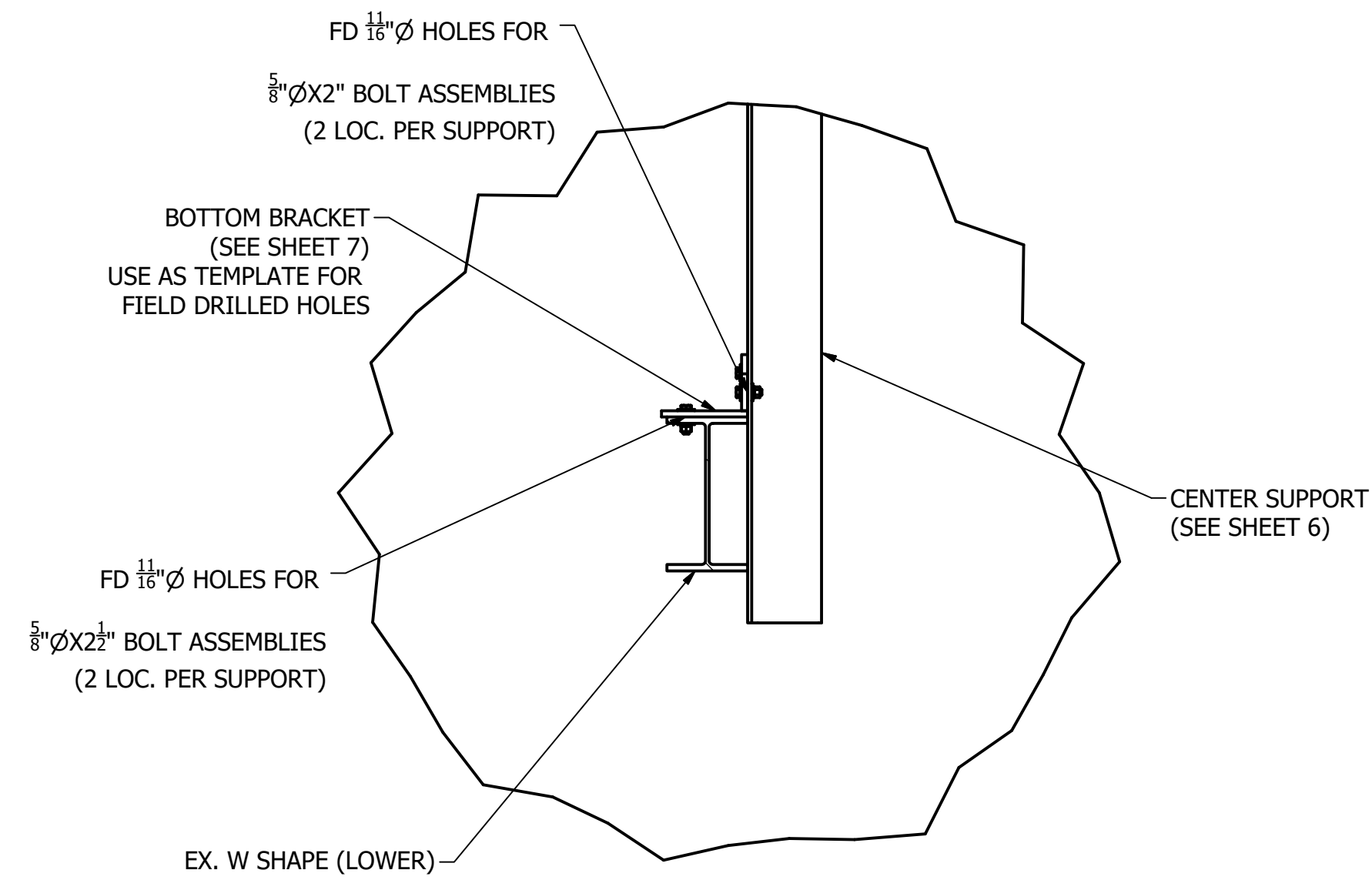

**DETAIL R**  
 SCALE 1"=1'-0"

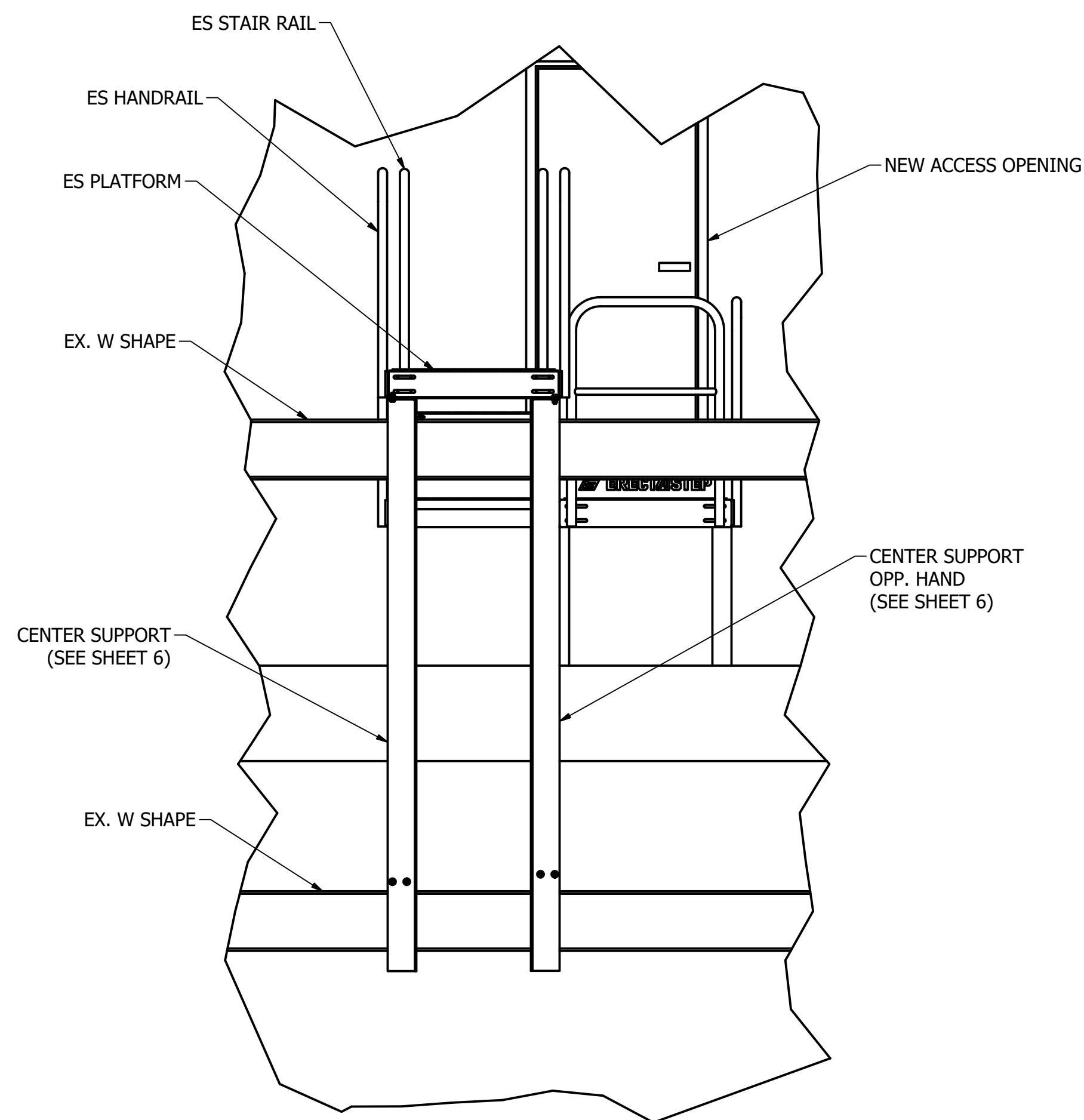

**DETAIL Y-Y**  
 SCALE 1"=2'-0"

**REVISIONS:**

REV	REVISION ISSUE	DATE
A	ISSUED FOR APPROVAL	04/24/23
B	ISSUED FOR APPROVAL	06/30/23
C	ISSUED FOR APPROVAL	09/11/24
D	ISSUED FOR CONSTRUCTION	09/11/24

**SHEET DESCRIPTION:**

DETAIL VIEWS

**SHEET 4 OF 12**

THIS DRAWING IS THE PROPERTY OF INDUSTRIAL TURNAROUND CORPORATION AND IS SUPPLIED FOR USE ONLY FOR AN AUTHORIZED PROJECT. THIS DRAWING CONTAINS CONFIDENTIAL AND PROPRIETARY INFORMATION OF INDUSTRIAL TURNAROUND CORPORATION AND SHALL NOT BE DISCLOSED, USED, COPIED OR REPRODUCED EITHER WHOLLY OR IN PART, EXCEPT IN CONNECTION WITH SUCH USE AND WITH THE PRIOR WRITTEN CONSENT OF INDUSTRIAL TURNAROUND CORPORATION. THIS DRAWING MUST NOT BE USED FOR CONSTRUCTION OR FABRICATION UNTIL SIGNED AS CHECKED AND ISSUED FOR CONSTRUCTION.

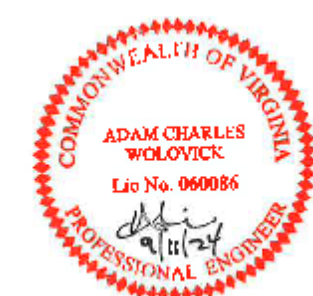

**DRAWING NOTES:**

STEEL SUPPORT STRUCTURE  
 DESIGNED TO FIT PROPOSED  
 ERECTSTEP COMPONENTS

ALL FABRICATED PARTS TO  
 BE PAINTED SAFETY YELLOW

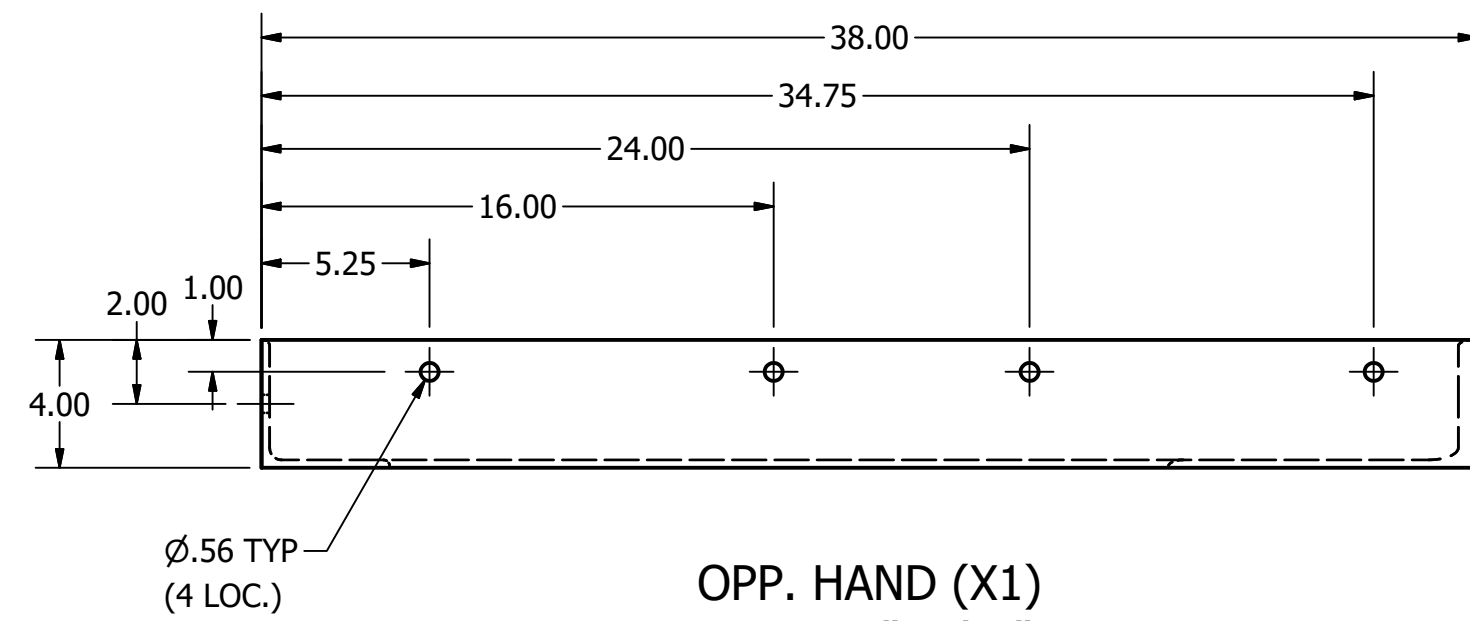

OPP. HAND (X1)  
 SCALE 1"=0'-6"

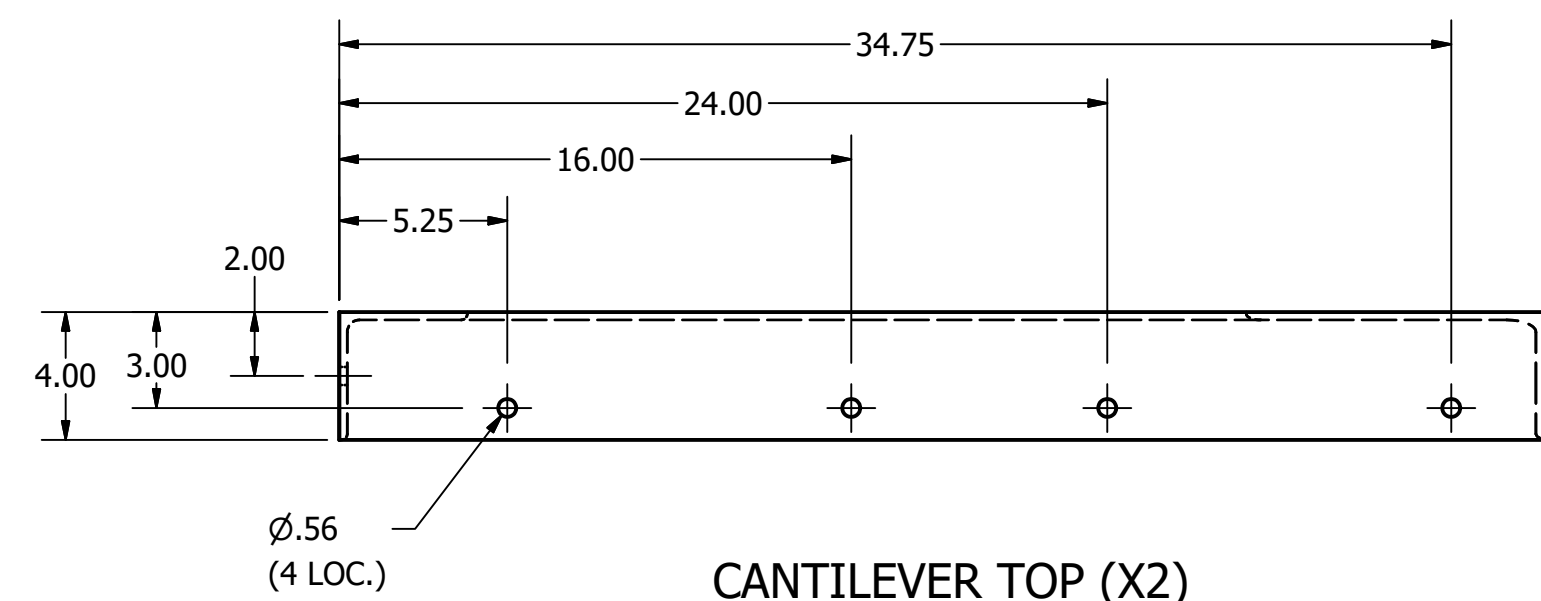

CANTILEVER TOP (X2)  
 SCALE 1"=0'-6"

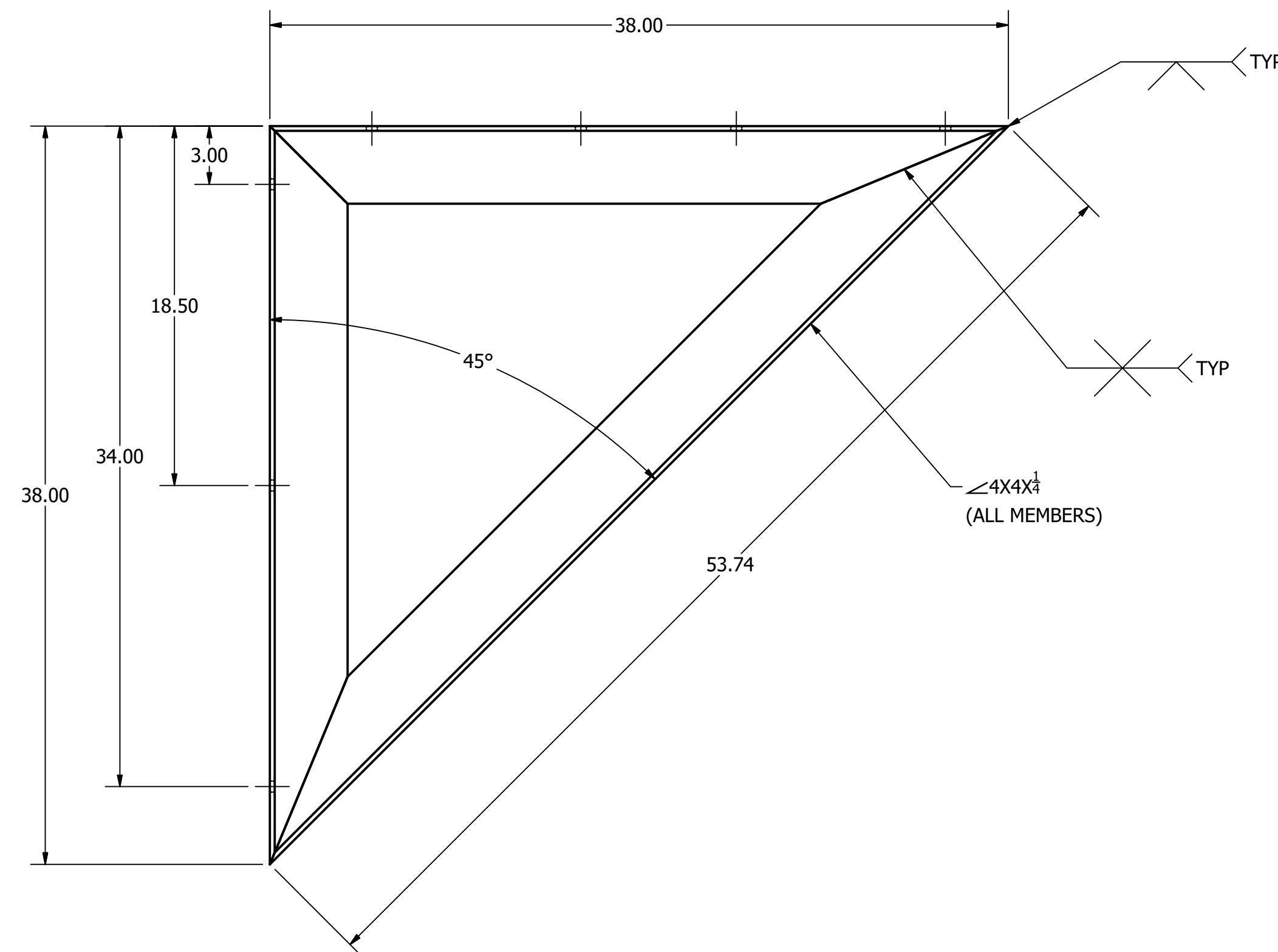

CANTILEVER SIDE (X2)  
 SCALE 1"=0'-6"

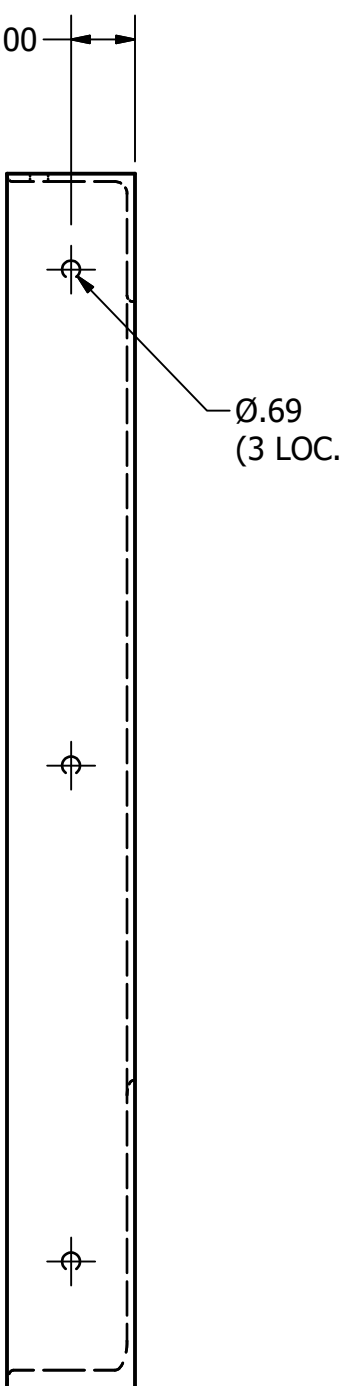

CANTILEVER FRONT (X2)  
 SCALE 1"=0'-6"

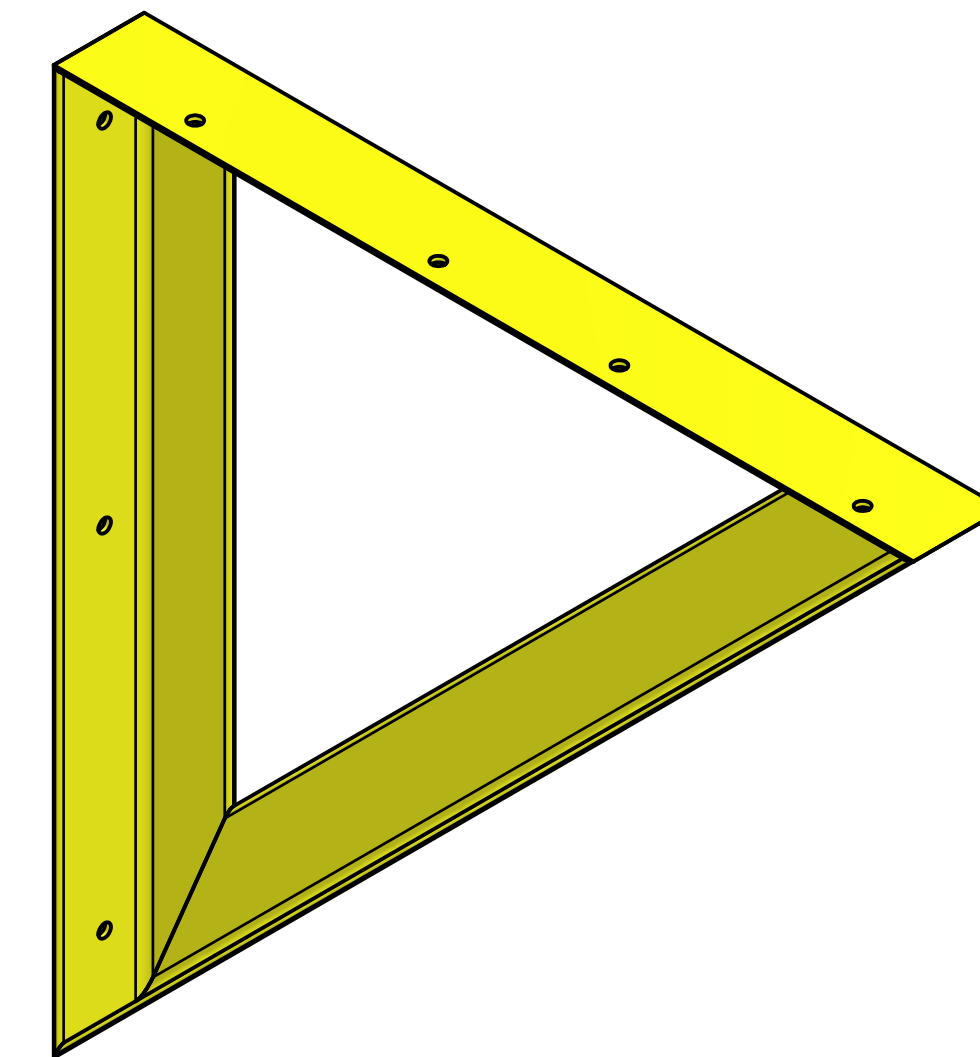

CANTILEVER ISO (X2)  
 SCALE 1 / 6

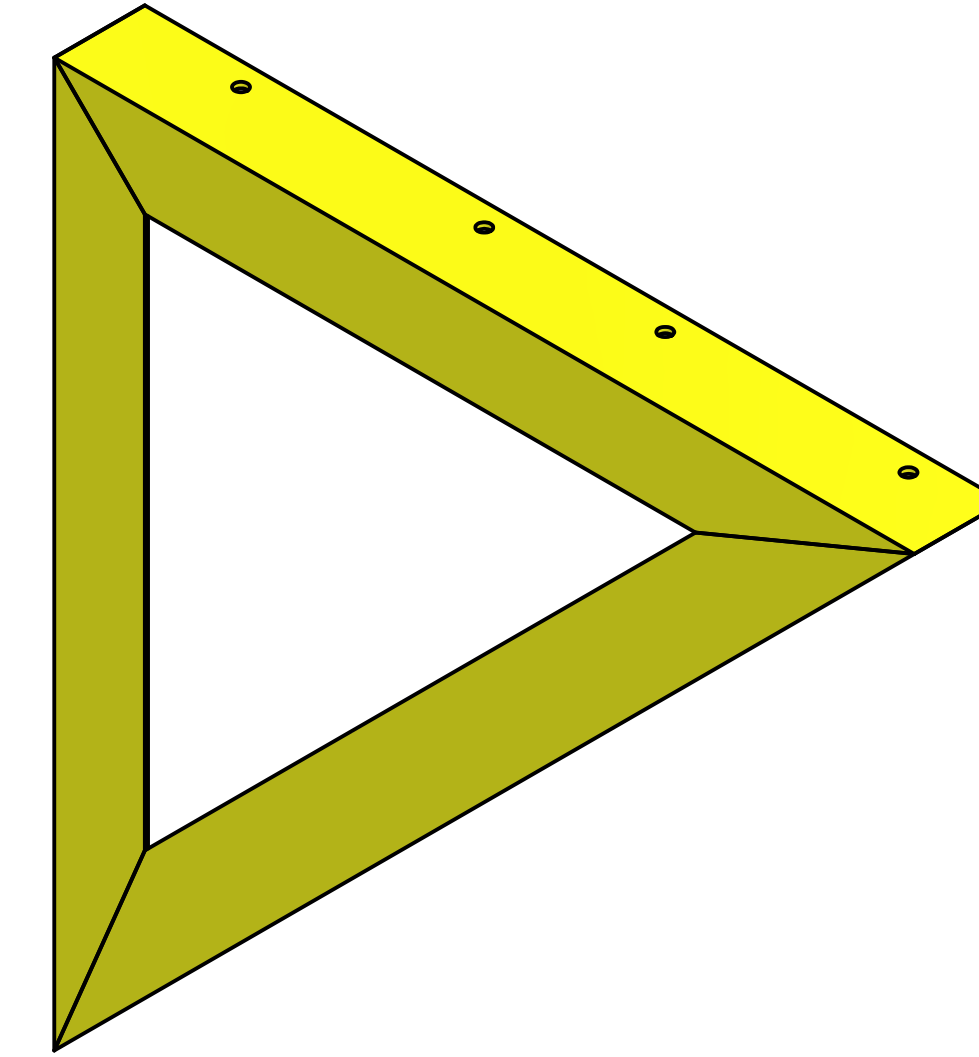

OPP. HAND (X1)  
 SCALE 1 / 6

**REVISIONS:**

REV	REVISION ISSUE	DATE
A	ISSUED FOR APPROVAL	04/24/23
B	ISSUED FOR APPROVAL	06/30/23
C	ISSUED FOR APPROVAL	09/11/24
0	ISSUED FOR CONSTRUCTION	09/11/24

**SHEET DESCRIPTION:**

CANTILEVER FABRICATION

**SHEET 5 OF 12**

THIS DRAWING IS THE PROPERTY OF INDUSTRIAL TURNAROUND CORPORATION AND IS SUPPLIED FOR USE ONLY FOR AN AUTHORIZED PROJECT. THIS DRAWING CONTAINS CONFIDENTIAL AND PROPRIETARY INFORMATION OF INDUSTRIAL TURNAROUND CORPORATION AND SHALL NOT BE DISCLOSED, USED, COPIED OR REPRODUCED EITHER WHOLLY OR IN PART, EXCEPT IN CONNECTION WITH SUCH USE AND WITH THE PRIOR WRITTEN CONSENT OF INDUSTRIAL TURNAROUND CORPORATION. THIS DRAWING MUST NOT BE USED FOR CONSTRUCTION OR FABRICATION UNTIL SIGNED AS CHECKED AND ISSUED FOR CONSTRUCTION.

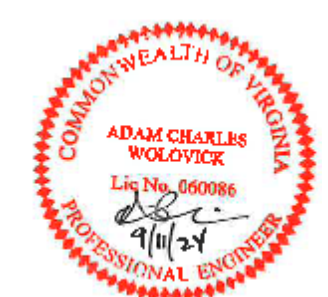

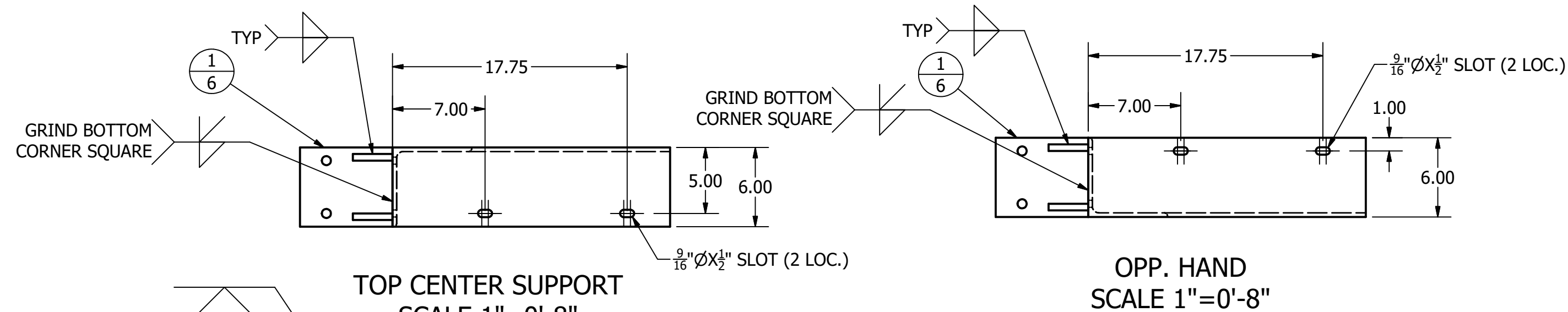

TOP CENTER SUPPORT  
 SCALE 1"=0'-8"

OPP. HAND  
 SCALE 1"=0'-8"

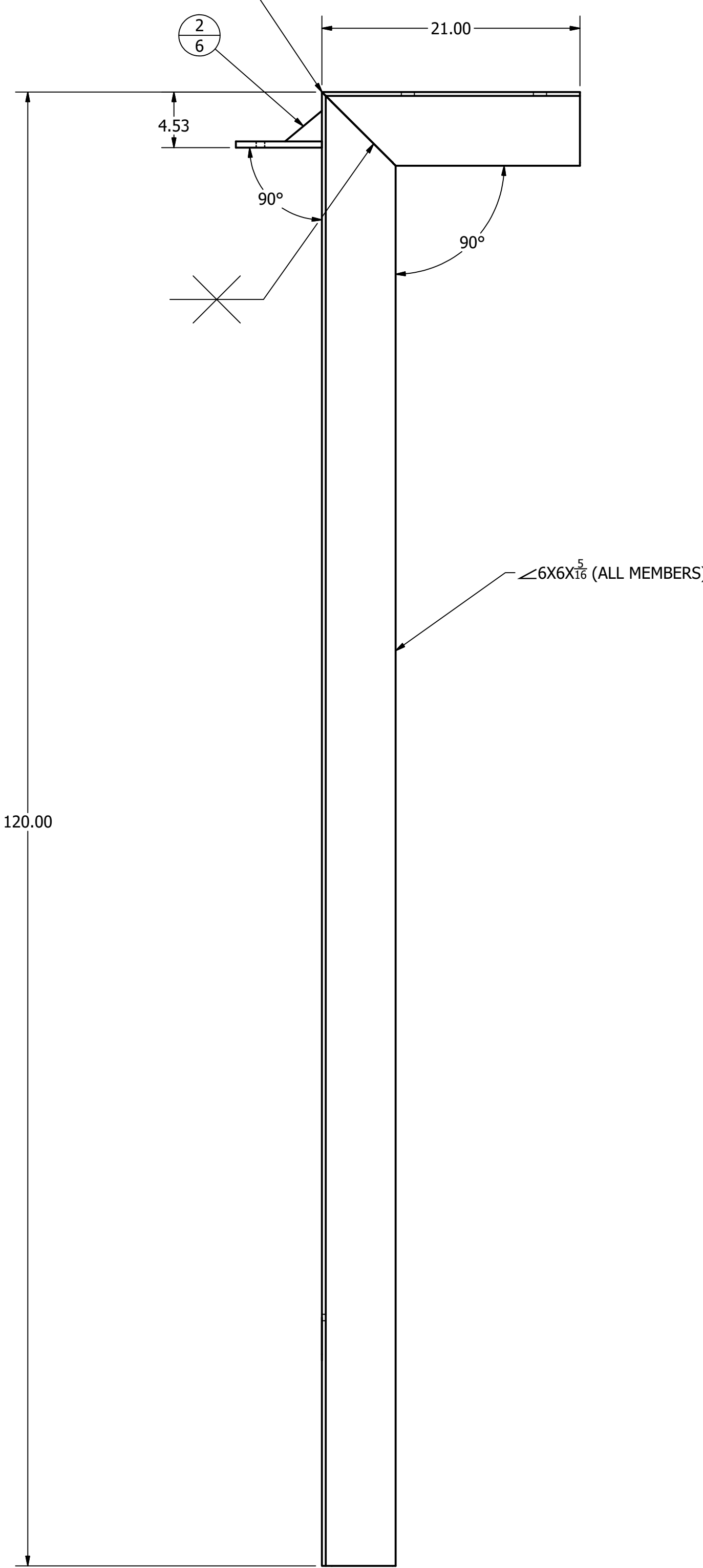

SIDE CENTER SUPPORT  
 SCALE 1"=0'-8"

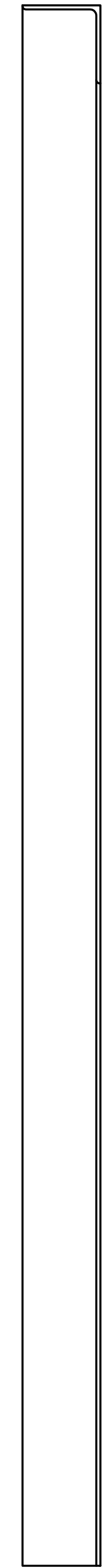

FRONT CENTER SUPPORT  
 SCALE 1"=0'-8"

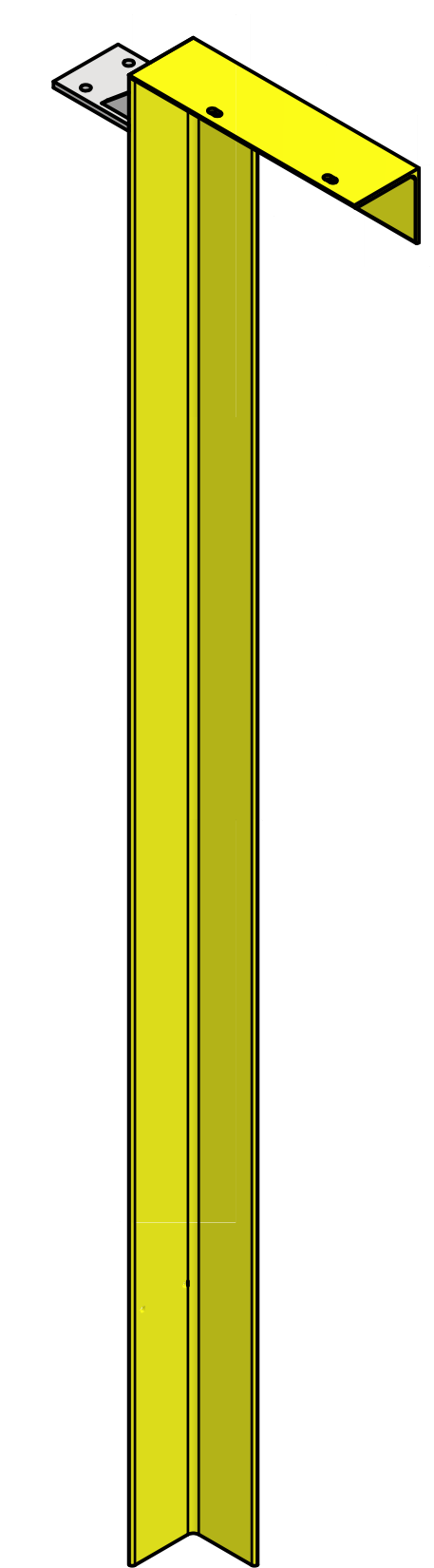

ISO CENTER SUPPORT  
 SCALE 1"=1'-0"

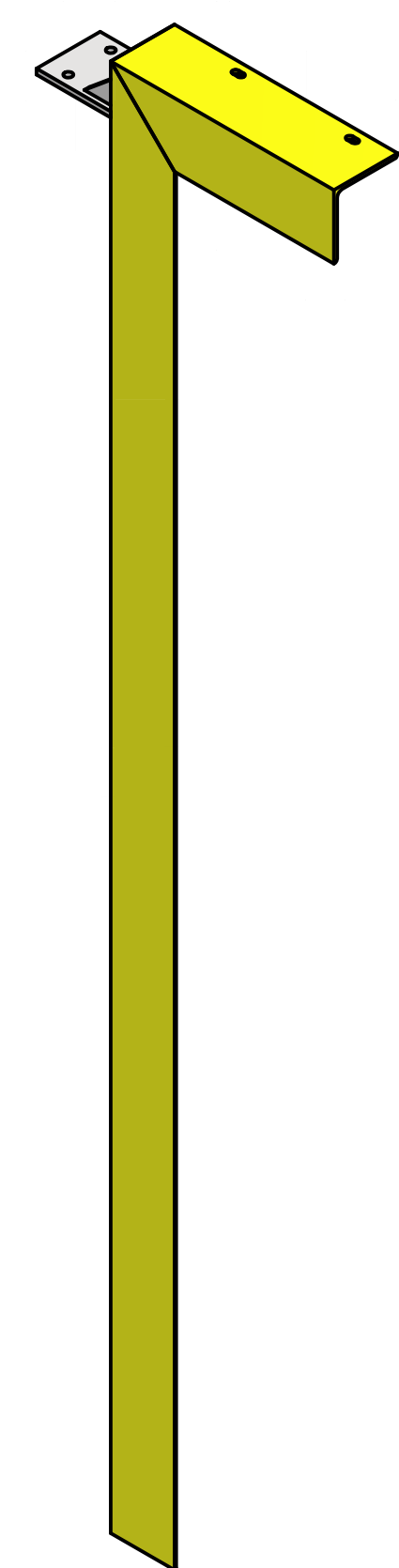

OPP. HAND  
 SCALE 1"=1'-0"

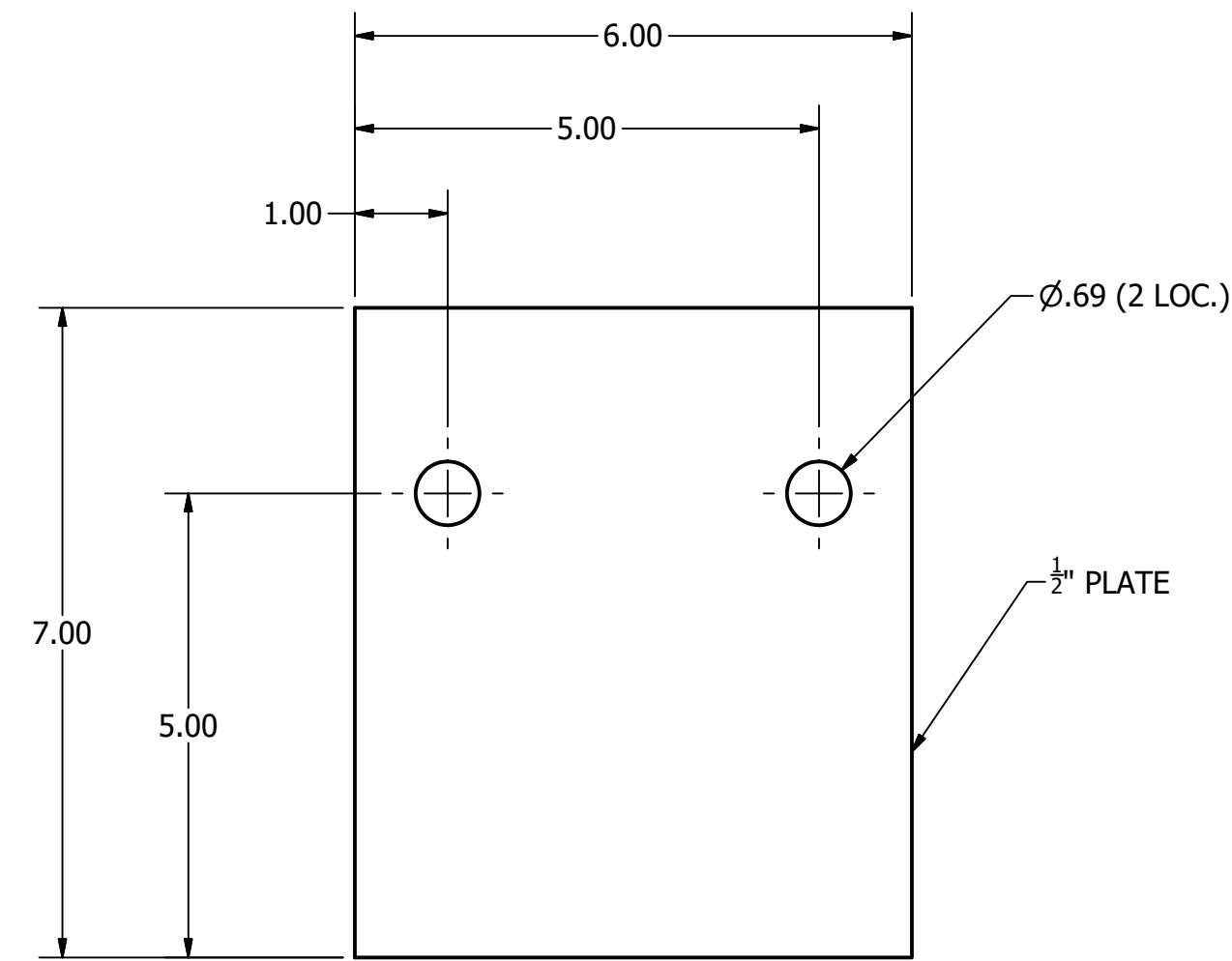

DETAIL 1: TAB  
 SCALE 1"=0'-2"

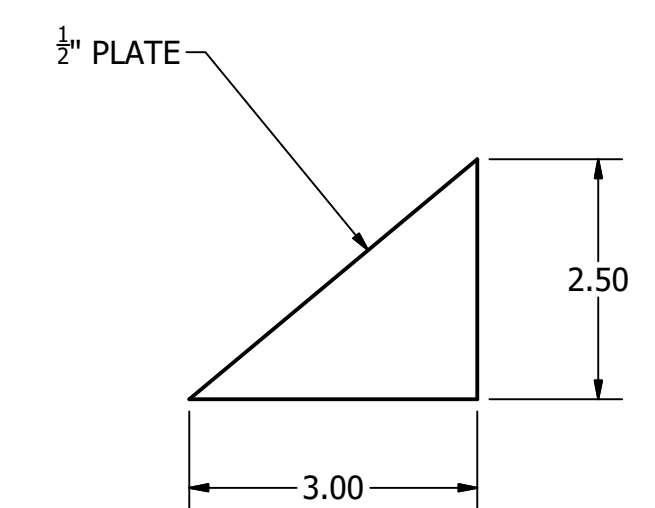

DETAIL 2  
 SCALE 1"=0'-2"

**REVISIONS:**

REV	REVISION ISSUE	DATE
A	ISSUED FOR APPROVAL	04/24/23
B	ISSUED FOR APPROVAL	06/30/23
C	ISSUED FOR APPROVAL	09/11/24
0	ISSUED FOR CONSTRUCTION	09/11/24

**SHEET DESCRIPTION:**  
 CENTER SUPPORT FABRICATION

**SHEET 6 OF 12**  
 THIS DRAWING IS THE PROPERTY OF INDUSTRIAL TURNAROUND CORPORATION AND IS SUPPLIED FOR USE ONLY FOR AN AUTHORIZED PROJECT. THIS DRAWING CONTAINS CONFIDENTIAL AND PROPRIETARY INFORMATION OF INDUSTRIAL TURNAROUND CORPORATION AND SHALL NOT BE DISCLOSED, USED, COPIED OR REPRODUCED EITHER WHOLLY OR IN PART, EXCEPT IN CONNECTION WITH SUCH USE AND WITH THE PRIOR WRITTEN CONSENT OF INDUSTRIAL TURNAROUND CORPORATION. THIS DRAWING MUST NOT BE USED FOR CONSTRUCTION OR FABRICATION UNTIL SIGNED AS CHECKED AND ISSUED FOR CONSTRUCTION.

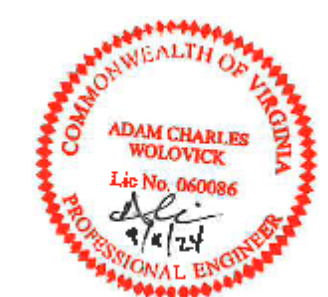

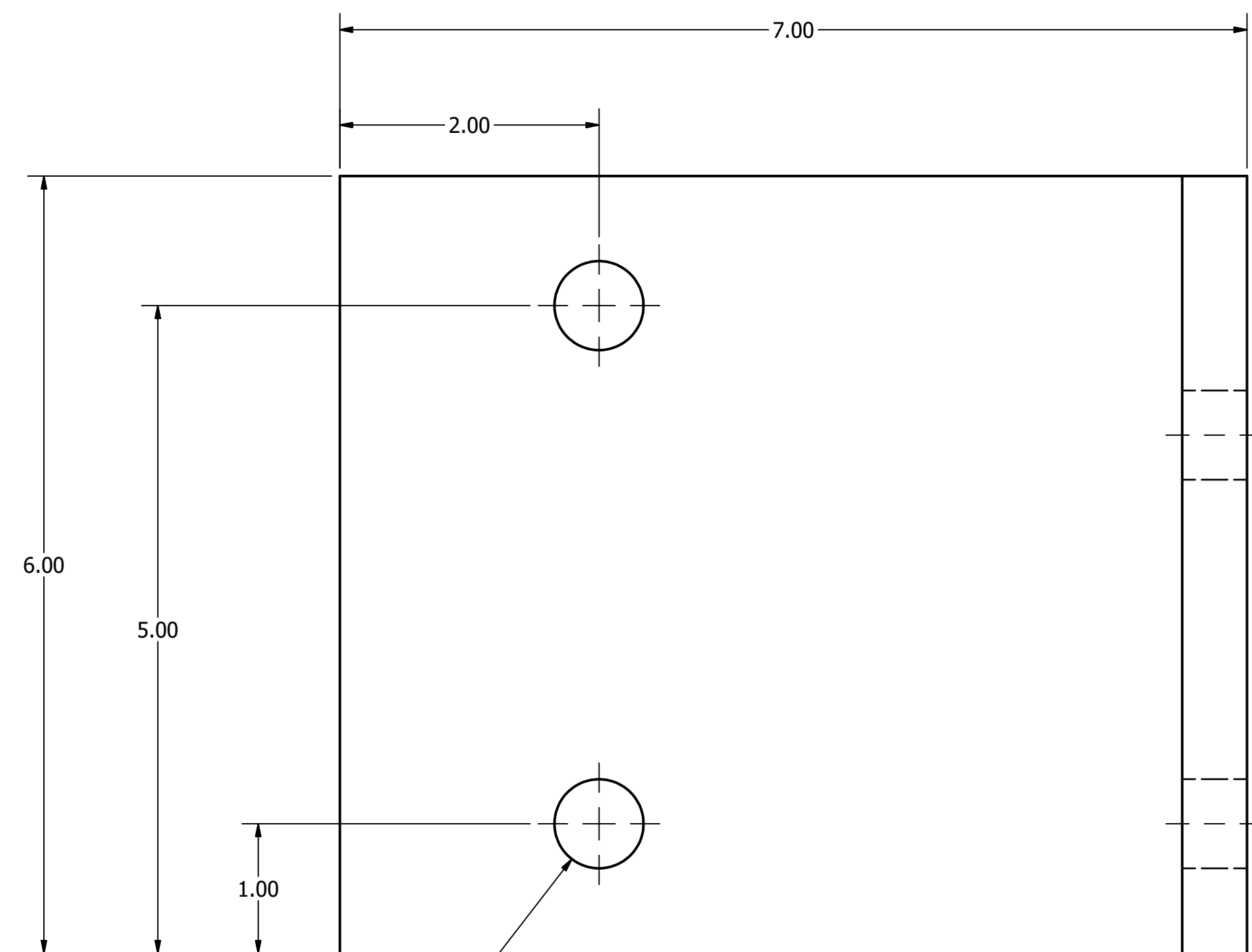

TOP BOTTOM BRACKET  
 SCALE 1"=0'-1"

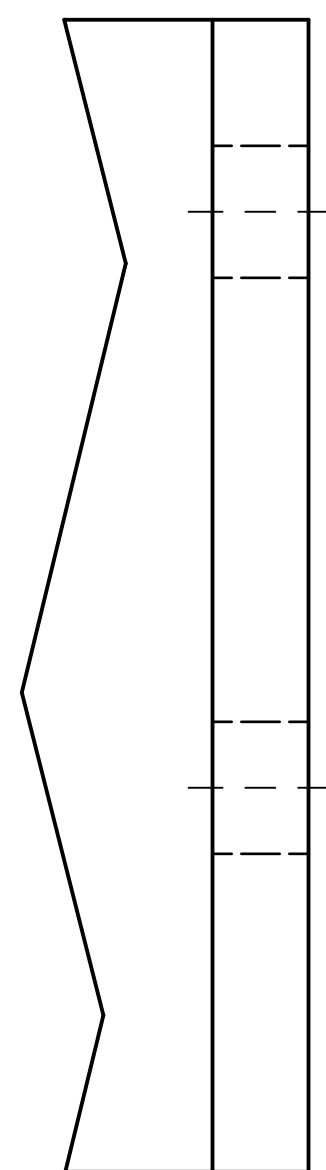

OPP. HAND  
 SCALE 1"=0'-1"

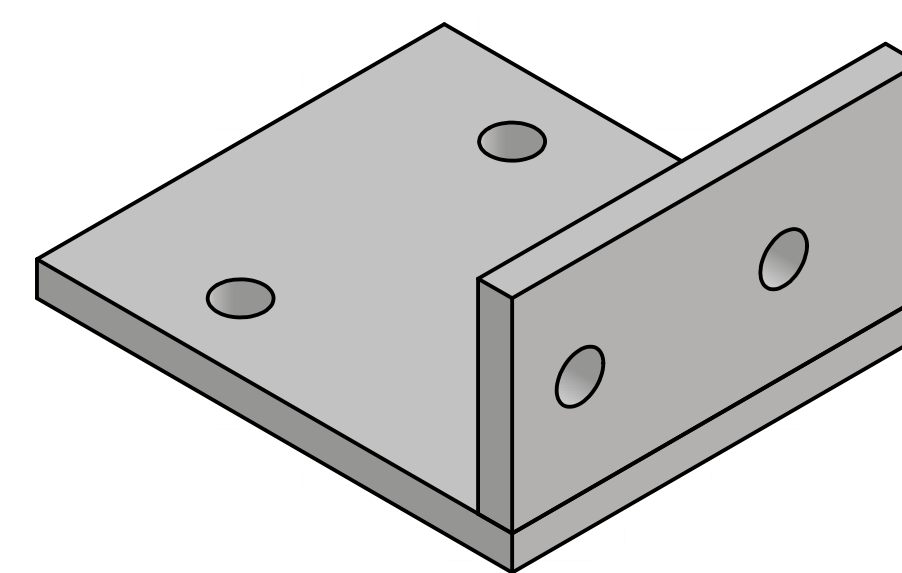

ISO BOTTOM BRACKET  
 SCALE 1"=0'-2"

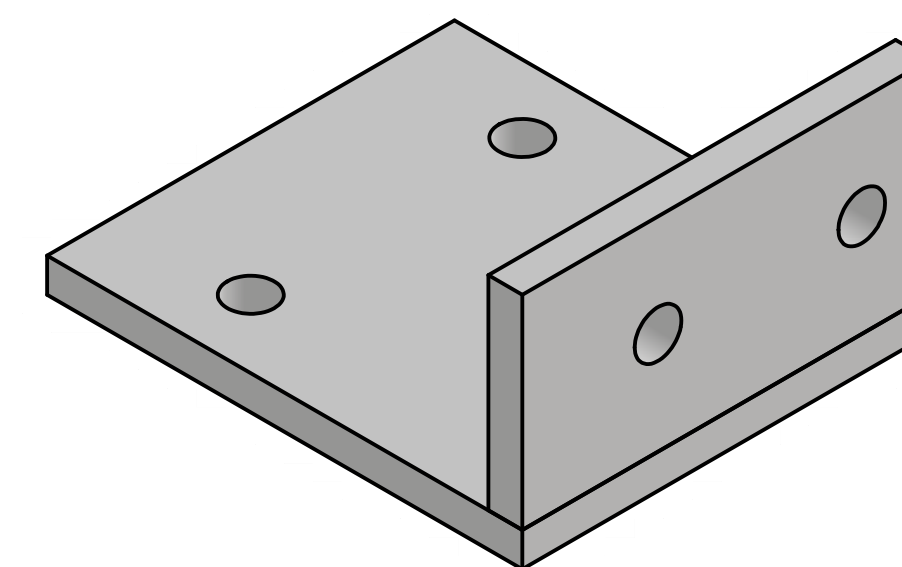

OPP. HAND  
 SCALE 1"=0'-2"

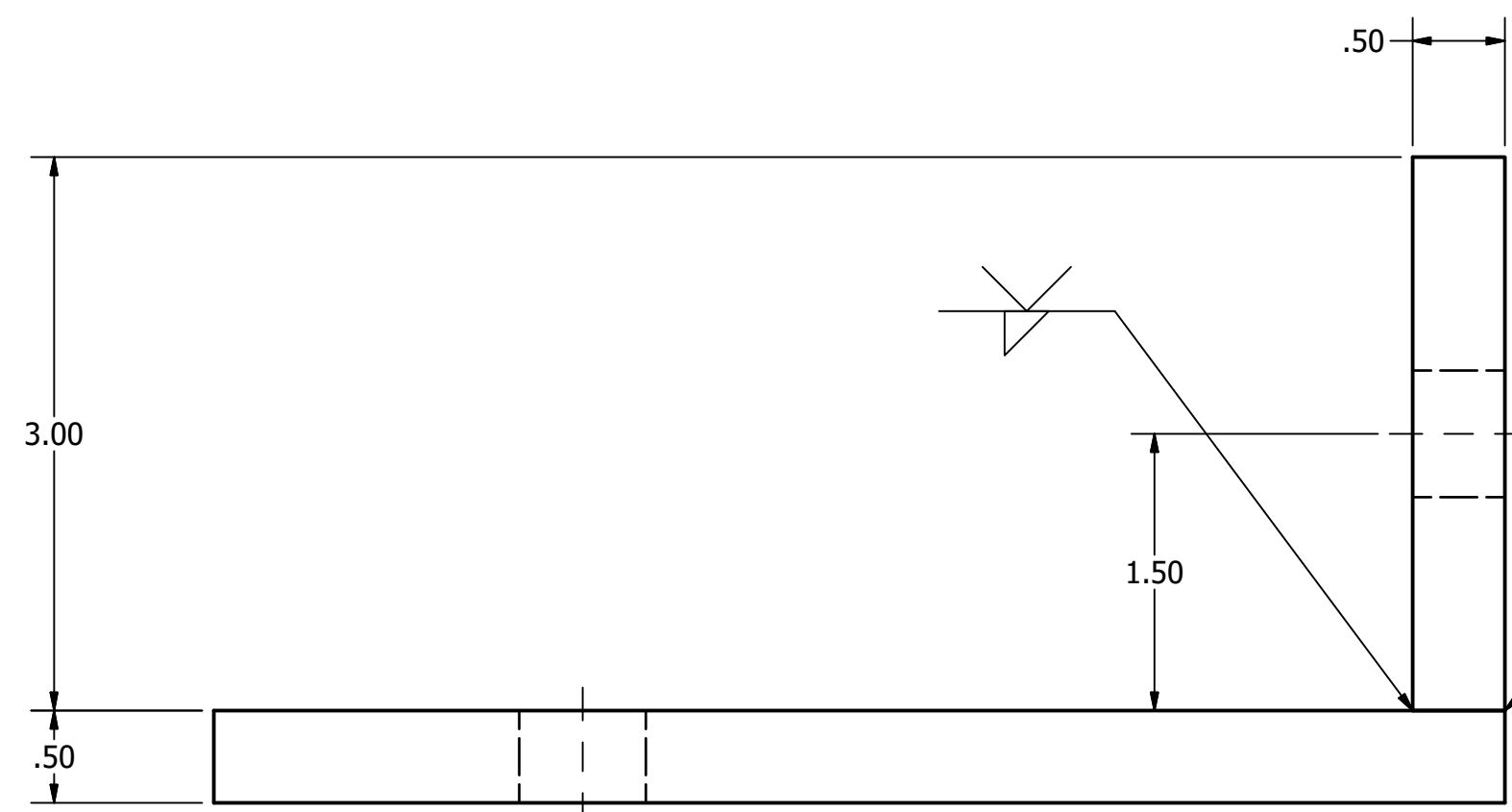

SIDE BOTTOM BRACKET  
 SCALE 1"=0'-1"

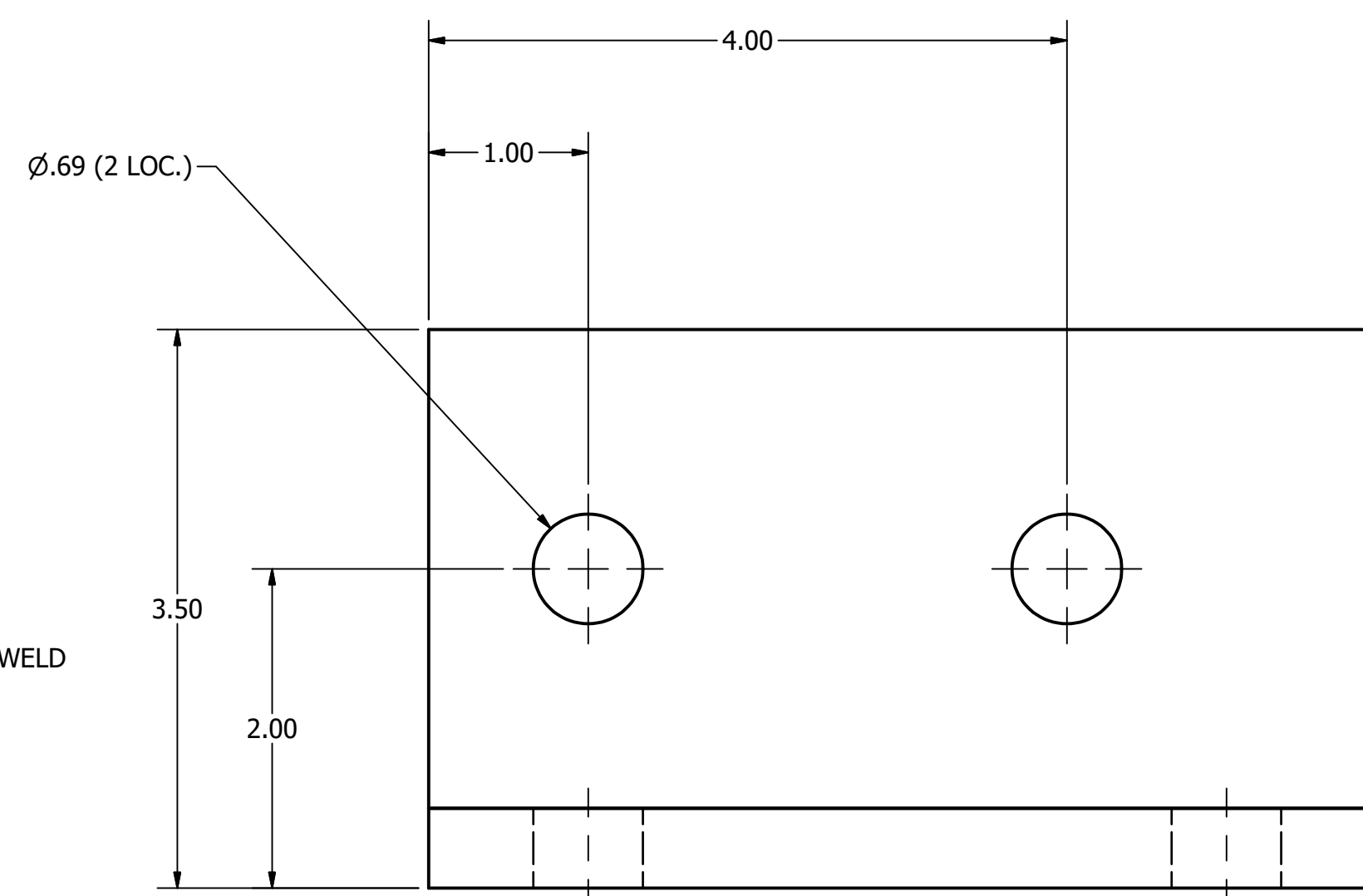

FRONT BOTTOM BRACKET  
 SCALE 1"=0'-1"

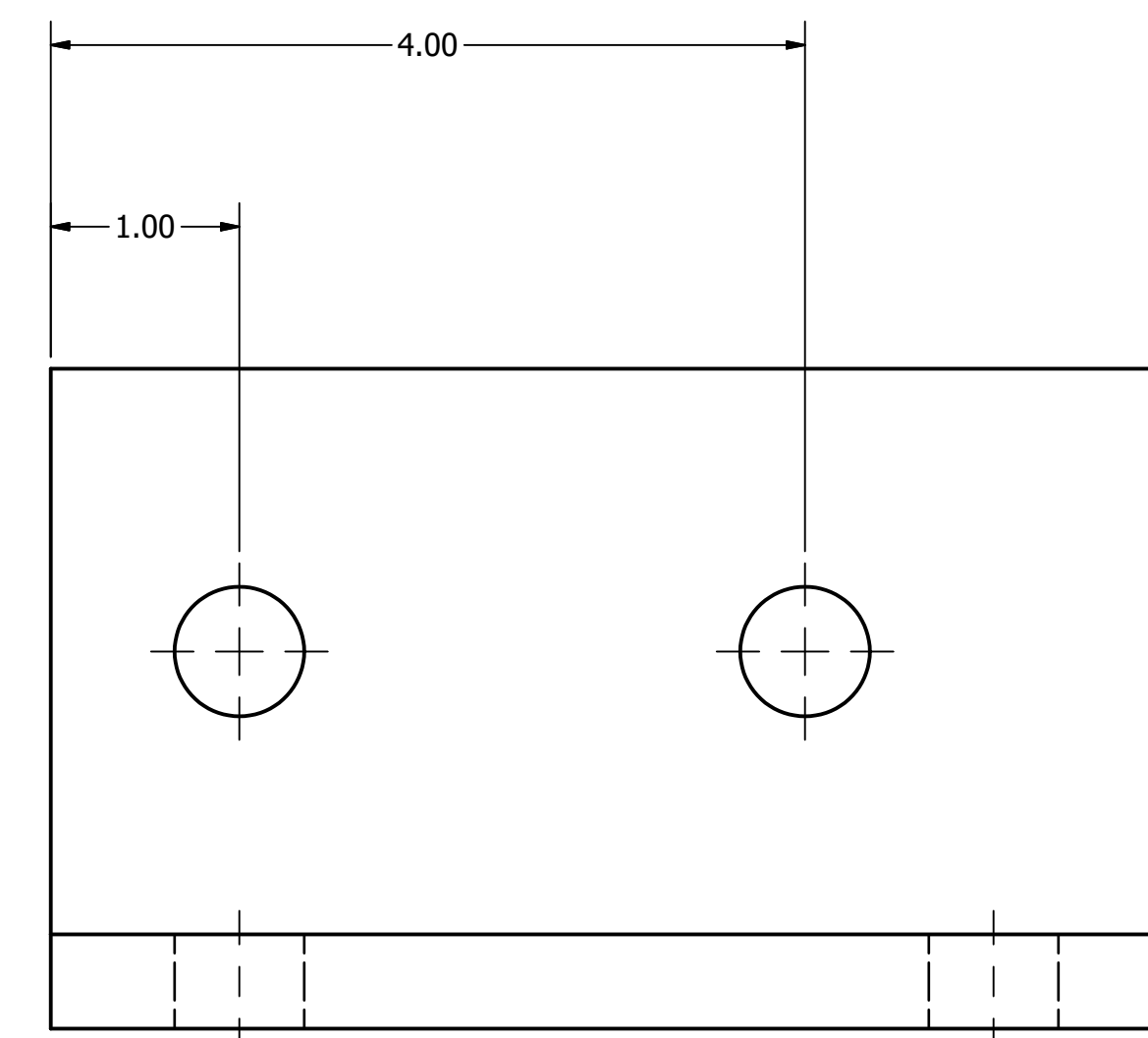

OPP. HAND  
 SCALE 1"=0'-1"

GRIND WELD  
 FLAT

**REVISIONS:**

REV	REVISION ISSUE	DATE
A	ISSUED FOR APPROVAL	04/24/23
B	ISSUED FOR APPROVAL	06/30/23
C	ISSUED FOR APPROVAL	09/11/24
0	ISSUED FOR CONSTRUCTION	09/11/24

**SHEET DESCRIPTION:**

BOTTOM BRACKET FABRICATION

**SHEET 7 OF 12**

THIS DRAWING IS THE PROPERTY OF INDUSTRIAL TURNAROUND CORPORATION AND IS SUPPLIED FOR USE ONLY FOR AN AUTHORIZED PROJECT. THIS DRAWING CONTAINS CONFIDENTIAL AND PROPRIETARY INFORMATION OF INDUSTRIAL TURNAROUND CORPORATION AND SHALL NOT BE DISCLOSED, USED, COPIED OR REPRODUCED EITHER WHOLLY OR IN PART, EXCEPT IN CONNECTION WITH SUCH USE AND WITH THE PRIOR WRITTEN CONSENT OF INDUSTRIAL TURNAROUND CORPORATION. THIS DRAWING MUST NOT BE USED FOR CONSTRUCTION OR FABRICATION UNTIL SIGNED AS CHECKED AND ISSUED FOR CONSTRUCTION.

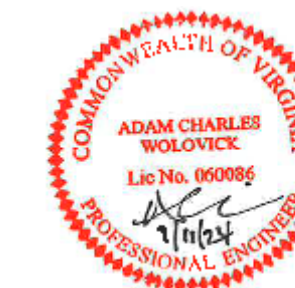

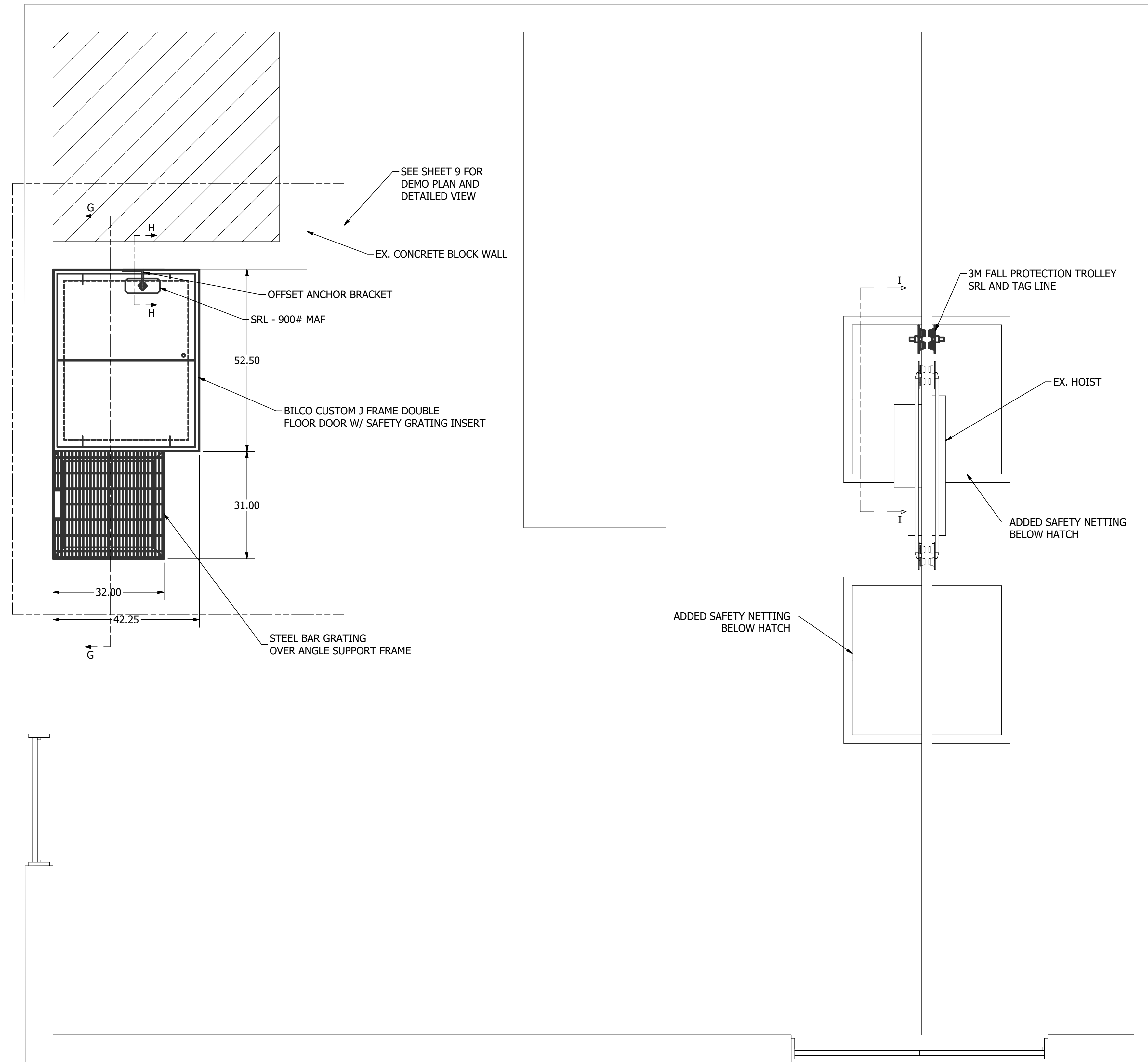

PLAN - TOP HATCHES  
 SCALE 1"=1'-6"

**REVISIONS:**

REV	REVISION ISSUE	DATE
A	ISSUED FOR APPROVAL	04/24/23
B	ISSUED FOR APPROVAL	06/30/23
C	ISSUED FOR APPROVAL	09/11/24
0	ISSUED FOR CONSTRUCTION	09/11/24

**SHEET DESCRIPTION:**

PLAN - TOP HATCHES

**SHEET 8 OF 12**

THIS DRAWING IS THE PROPERTY OF INDUSTRIAL TURNAROUND CORPORATION AND IS SUPPLIED FOR USE ONLY FOR AN AUTHORIZED PROJECT. THIS DRAWING CONTAINS CONFIDENTIAL AND PROPRIETARY INFORMATION OF INDUSTRIAL TURNAROUND CORPORATION AND SHALL NOT BE DISCLOSED, USED, COPIED OR REPRODUCED EITHER WHOLLY OR IN PART, EXCEPT IN CONNECTION WITH SUCH USE AND WITH THE PRIOR WRITTEN CONSENT OF INDUSTRIAL TURNAROUND CORPORATION. THIS DRAWING MUST NOT BE USED FOR CONSTRUCTION OR FABRICATION UNTIL SIGNED AS CHECKED AND ISSUED FOR CONSTRUCTION.





**FLOOR DOOR SPECIFICATIONS**  
 ANTI-CORROSION FINISH  
 ANTI-SLIP SURFACE  
 FLUSH FIT  
 RATED AT 150PSF  
 REMOVABLE HANDLE  
 ASSISTED OPEN AND CLOSE MECHANISM  
 AUTOMATIC HOLD OPEN  
 REMOVABLE GRATING OR NETTING (OSHA COMPLIANT)

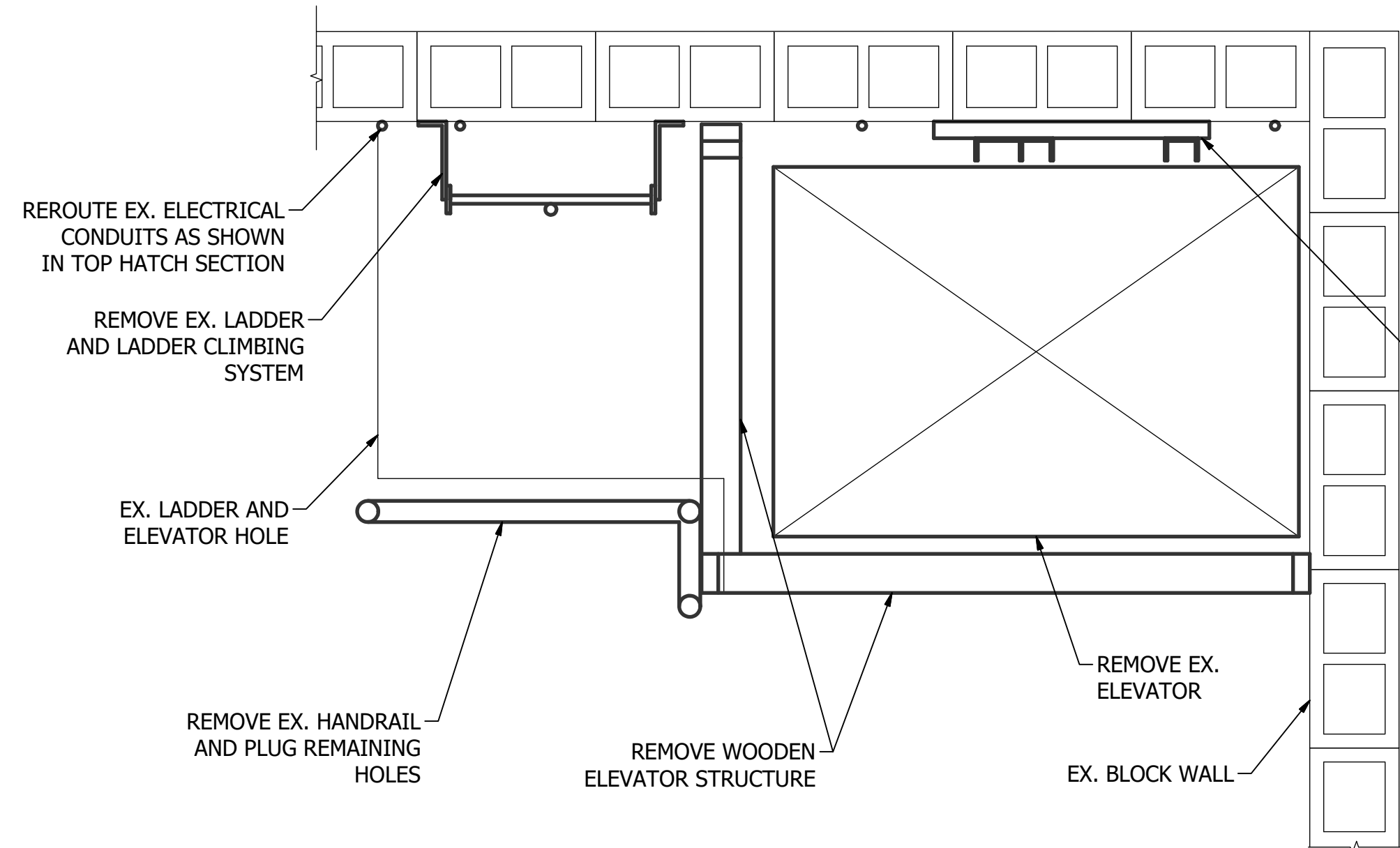

DEMO PLAN  
 SCALE 1"=1'-0"

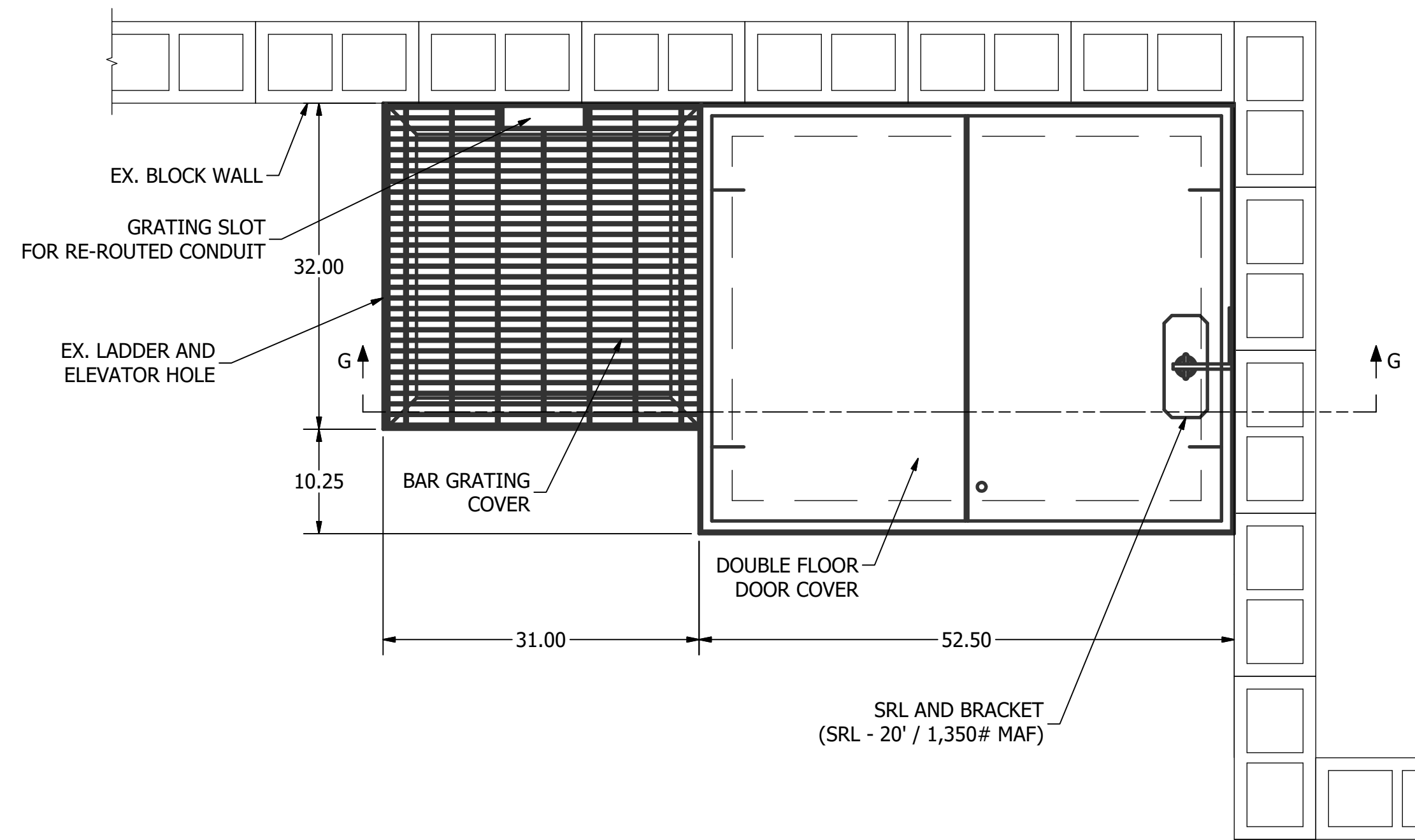

PLAN - TOP HATCH  
 SCALE 1"=1'-0"

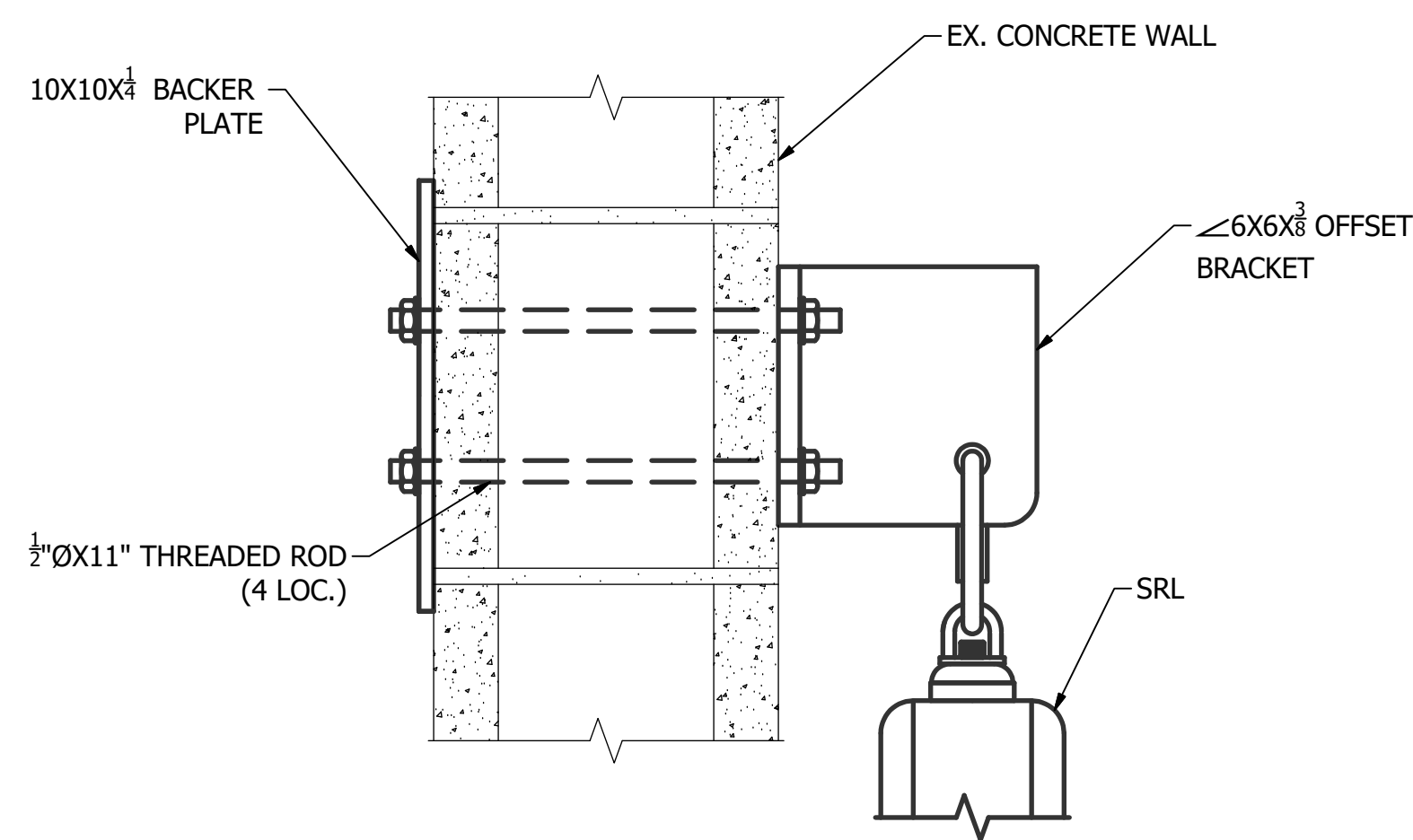

DETAIL - H-H SRL ATTACHMENT  
 SCALE 1"=0'-4"

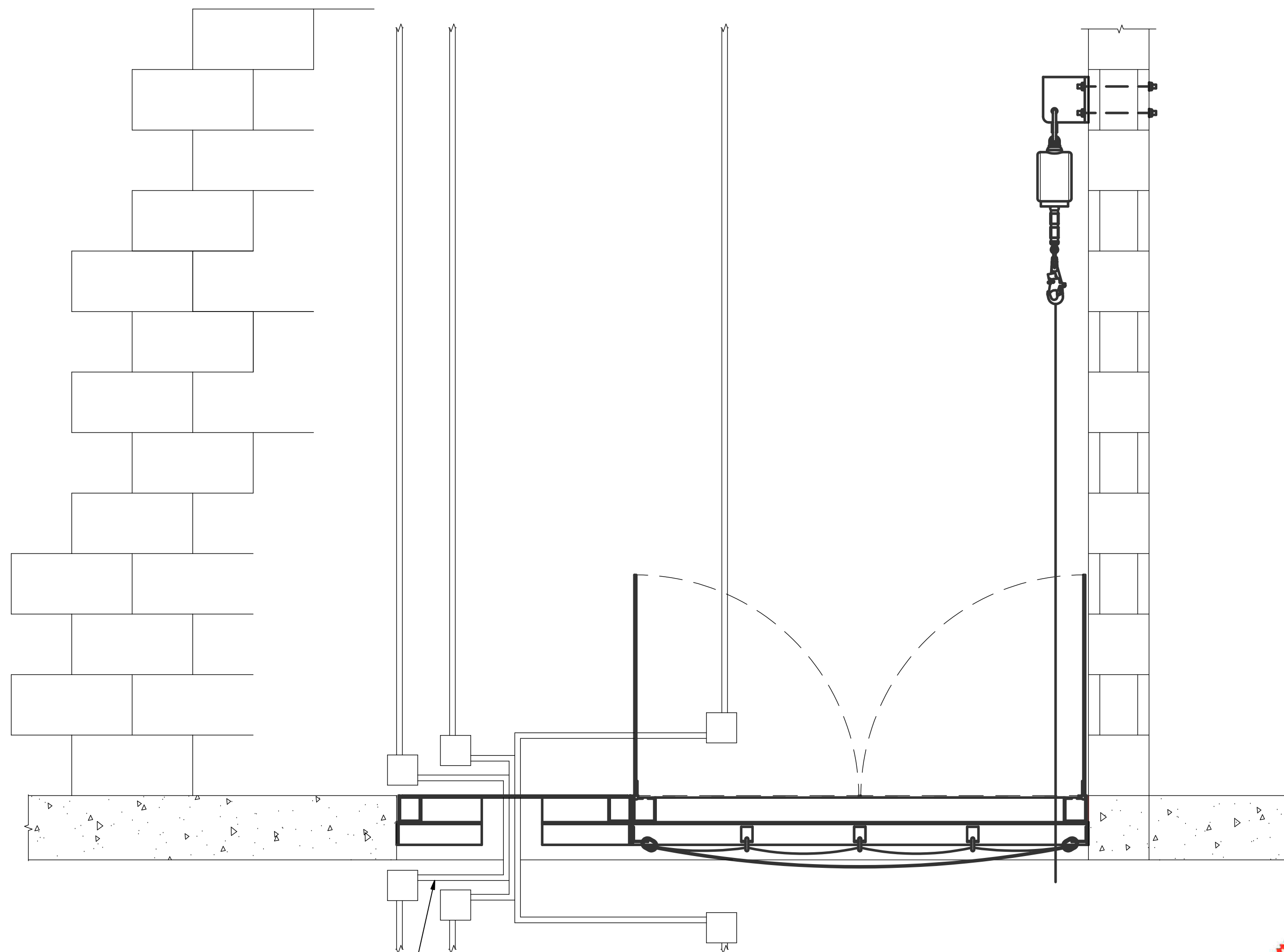

SECTION G-G - TOP HATCH  
 SCALE 1"=1'-0"

**REVISIONS:**

REV	REVISION ISSUE	DATE
A	ISSUED FOR APPROVAL	04/24/23
B	ISSUED FOR APPROVAL	06/30/23
C	ISSUED FOR APPROVAL	09/11/24
0	ISSUED FOR CONSTRUCTION	09/11/24

**SHEET DESCRIPTION:**  
 HATCH SECTION

SHEET 9 OF 12

THIS DRAWING IS THE PROPERTY OF INDUSTRIAL TURNAROUND CORPORATION AND IS SUPPLIED FOR USE ONLY FOR AN AUTHORIZED PROJECT. THIS DRAWING CONTAINS CONFIDENTIAL AND PROPRIETARY INFORMATION OF INDUSTRIAL TURNAROUND CORPORATION AND SHALL NOT BE DISCLOSED, USED, COPIED OR REPRODUCED EITHER WHOLLY OR IN PART, EXCEPT IN CONNECTION WITH SUCH USE AND WITH THE PRIOR WRITTEN CONSENT OF INDUSTRIAL TURNAROUND CORPORATION. THIS DRAWING MUST NOT BE USED FOR CONSTRUCTION OR FABRICATION UNTIL SIGNED AS CHECKED AND ISSUED FOR CONSTRUCTION.

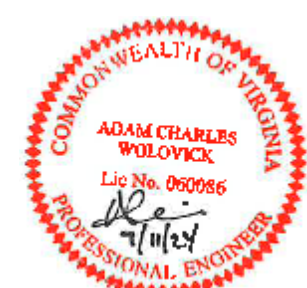

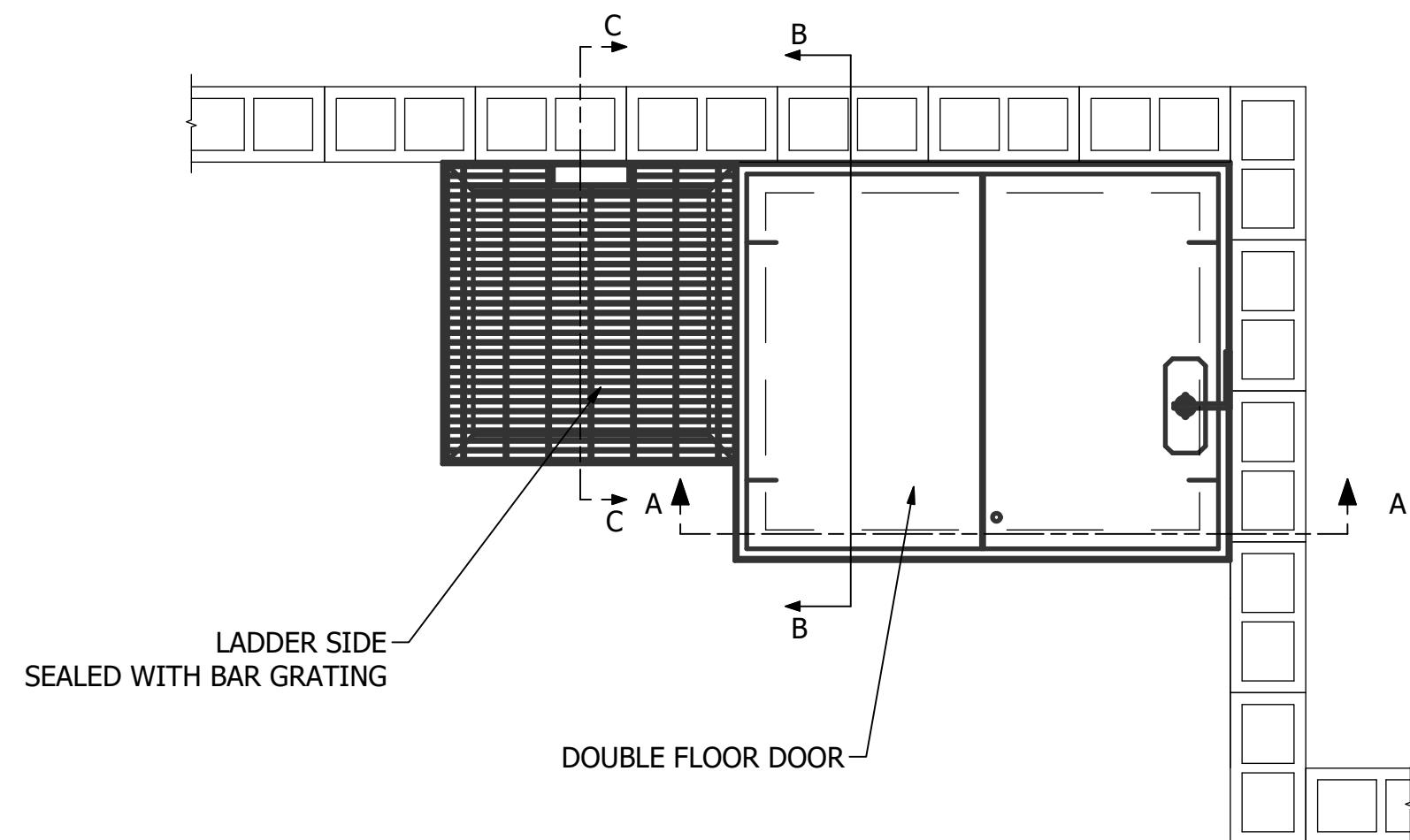

PLAN - NEW HATCH

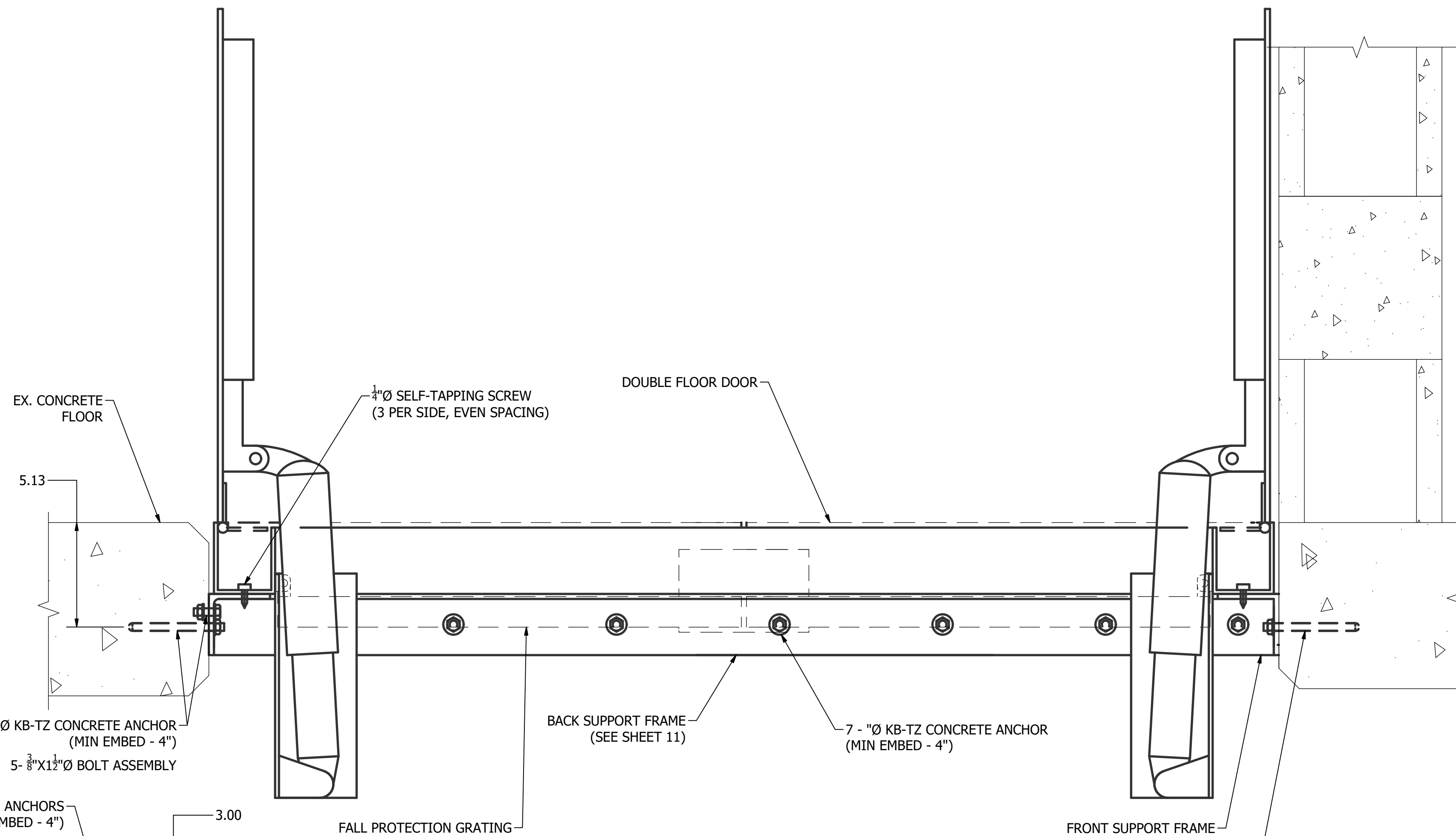

SECTION A-A

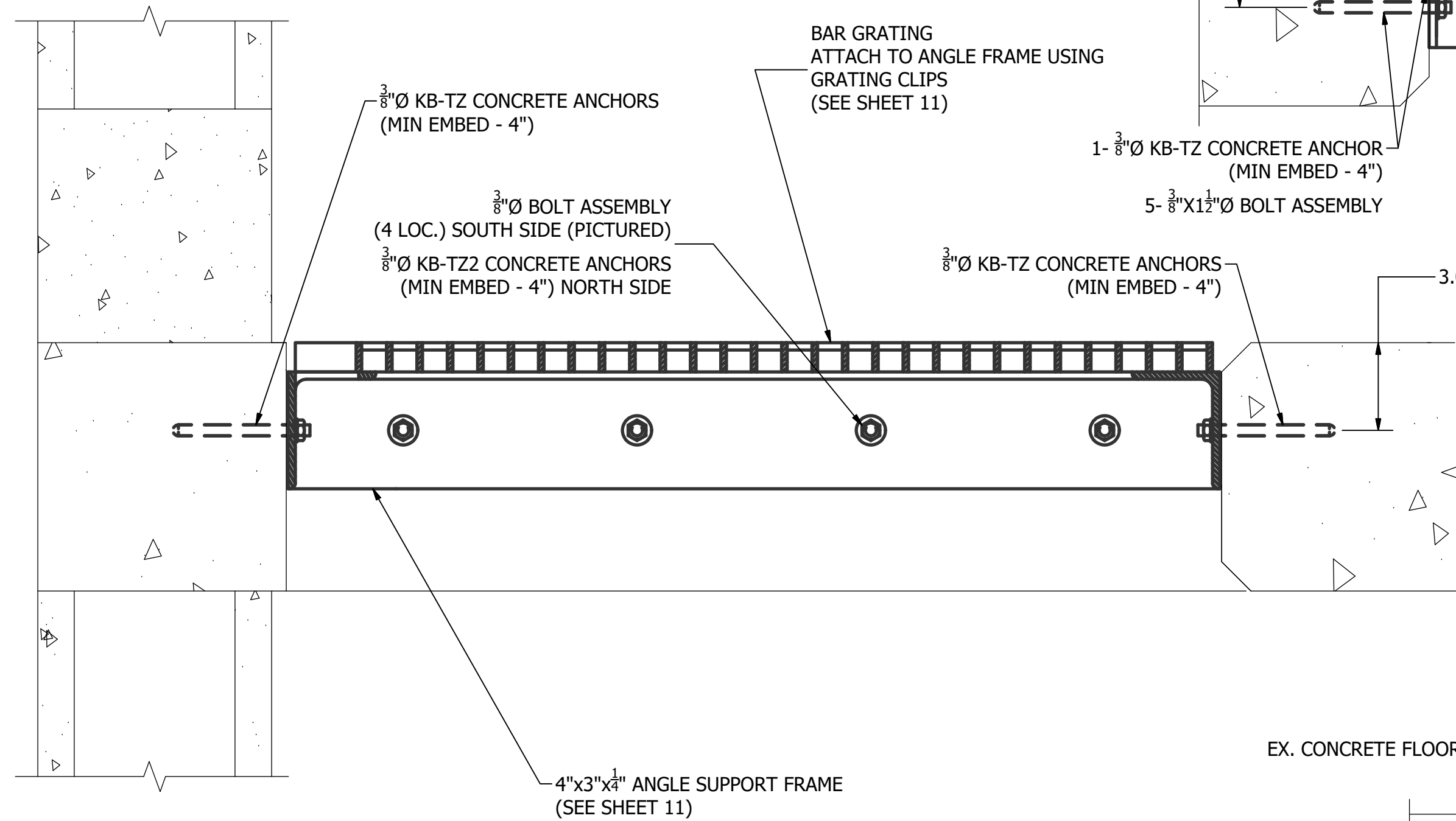

SECTION C-C

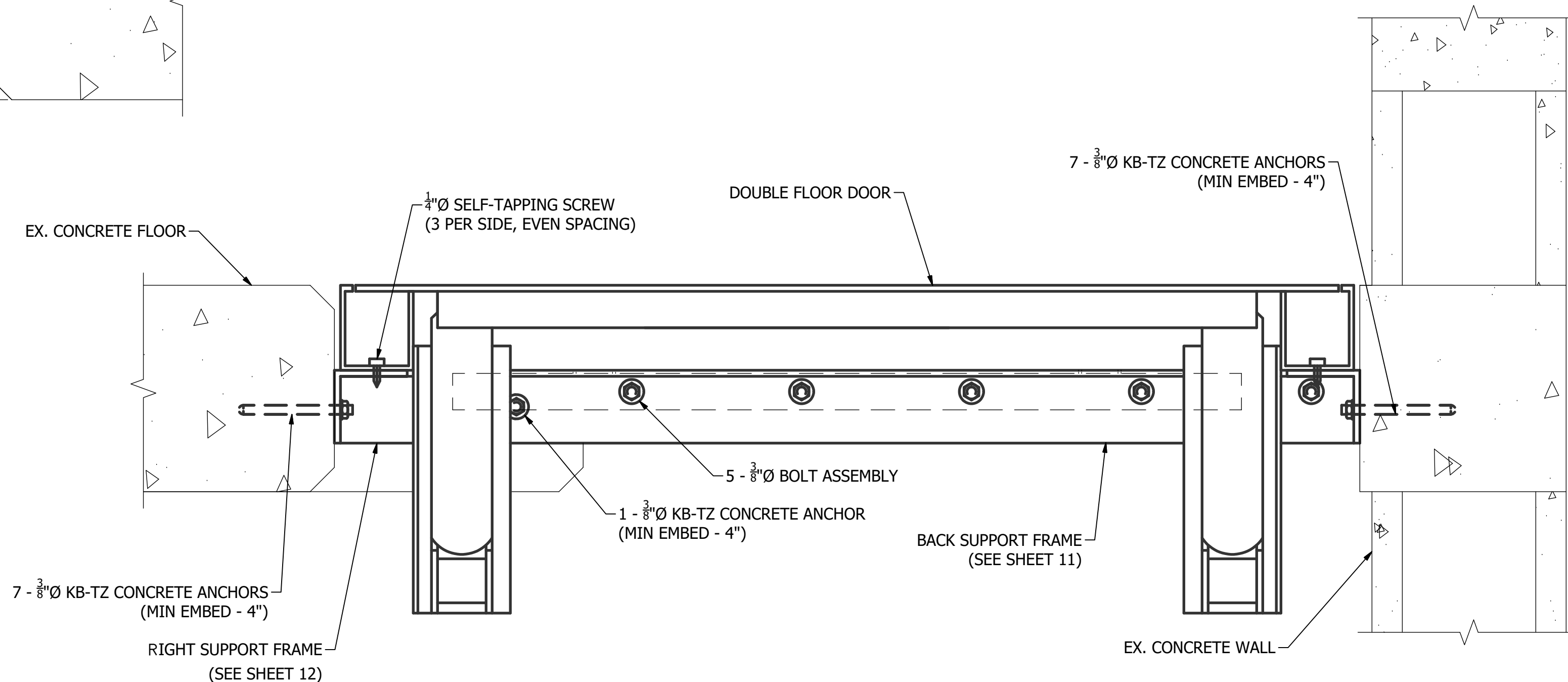

SECTION B-B

**REVISIONS:**

REV	REVISION ISSUE	DATE
A	ISSUED FOR APPROVAL	04/24/23
B	ISSUED FOR APPROVAL	06/30/23
C	ISSUED FOR APPROVAL	09/11/24
0	ISSUED FOR CONSTRUCTION	09/11/24

**SHEET DESCRIPTION:**

HATCH DETAILS

**SHEET 10 OF 12**

THIS DRAWING IS THE PROPERTY OF INDUSTRIAL TURNAROUND CORPORATION AND IS SUPPLIED FOR USE ONLY FOR AN AUTHORIZED PROJECT. THIS DRAWING CONTAINS CONFIDENTIAL AND PROPRIETARY INFORMATION OF INDUSTRIAL TURNAROUND CORPORATION AND SHALL NOT BE DISCLOSED, USED, COPIED OR REPRODUCED EITHER WHOLLY OR IN PART, EXCEPT IN CONNECTION WITH SUCH USE AND WITH THE PRIOR WRITTEN CONSENT OF INDUSTRIAL TURNAROUND CORPORATION. THIS DRAWING MUST NOT BE USED FOR CONSTRUCTION OR FABRICATION UNTIL SIGNED AS CHECKED AND ISSUED FOR CONSTRUCTION.

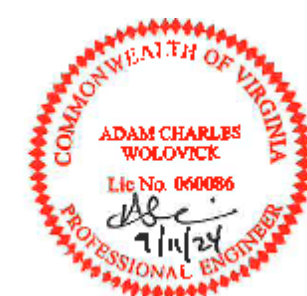

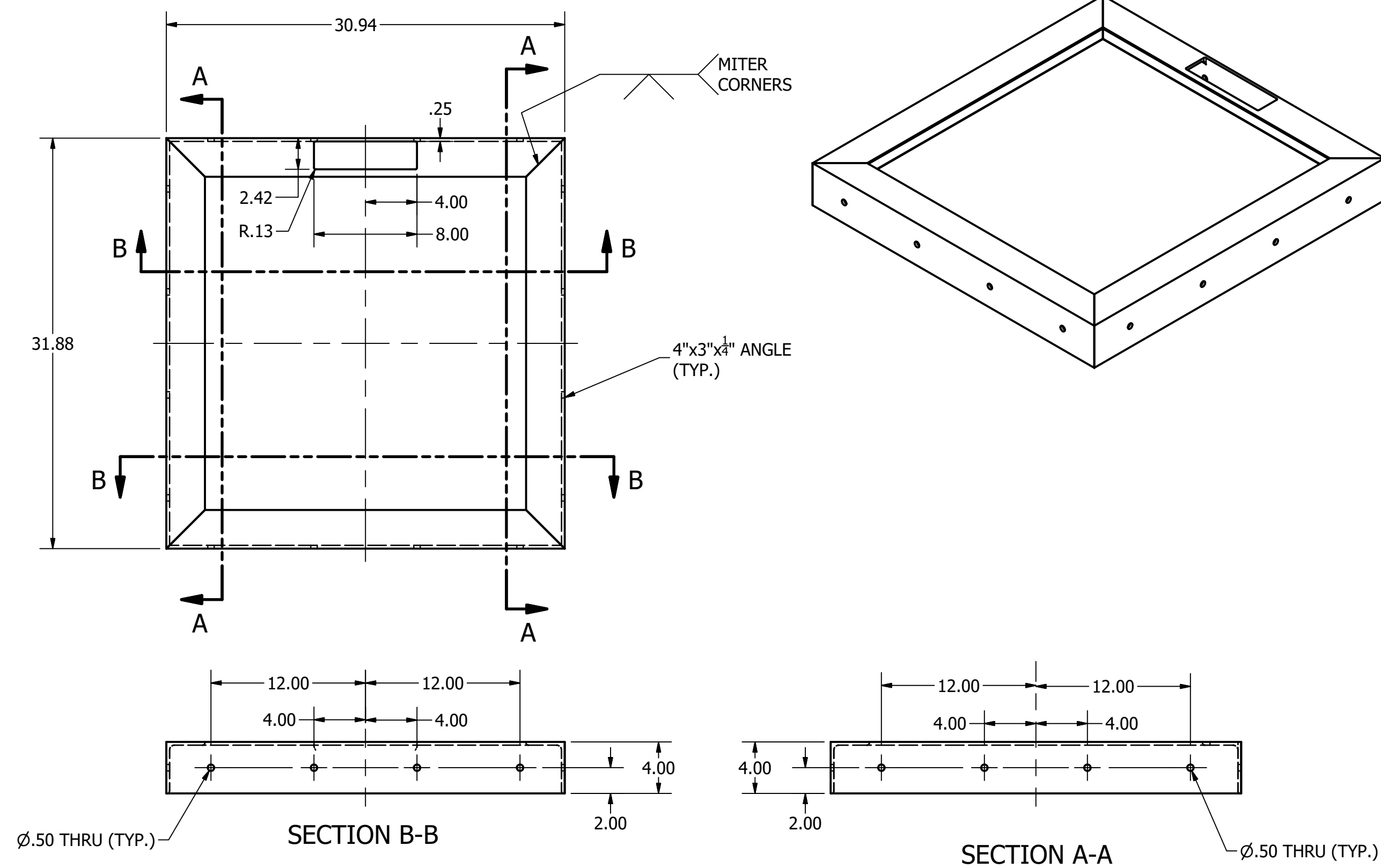

ANGLE SUPPORT FRAME  
 SCALE 1"=0'-8"

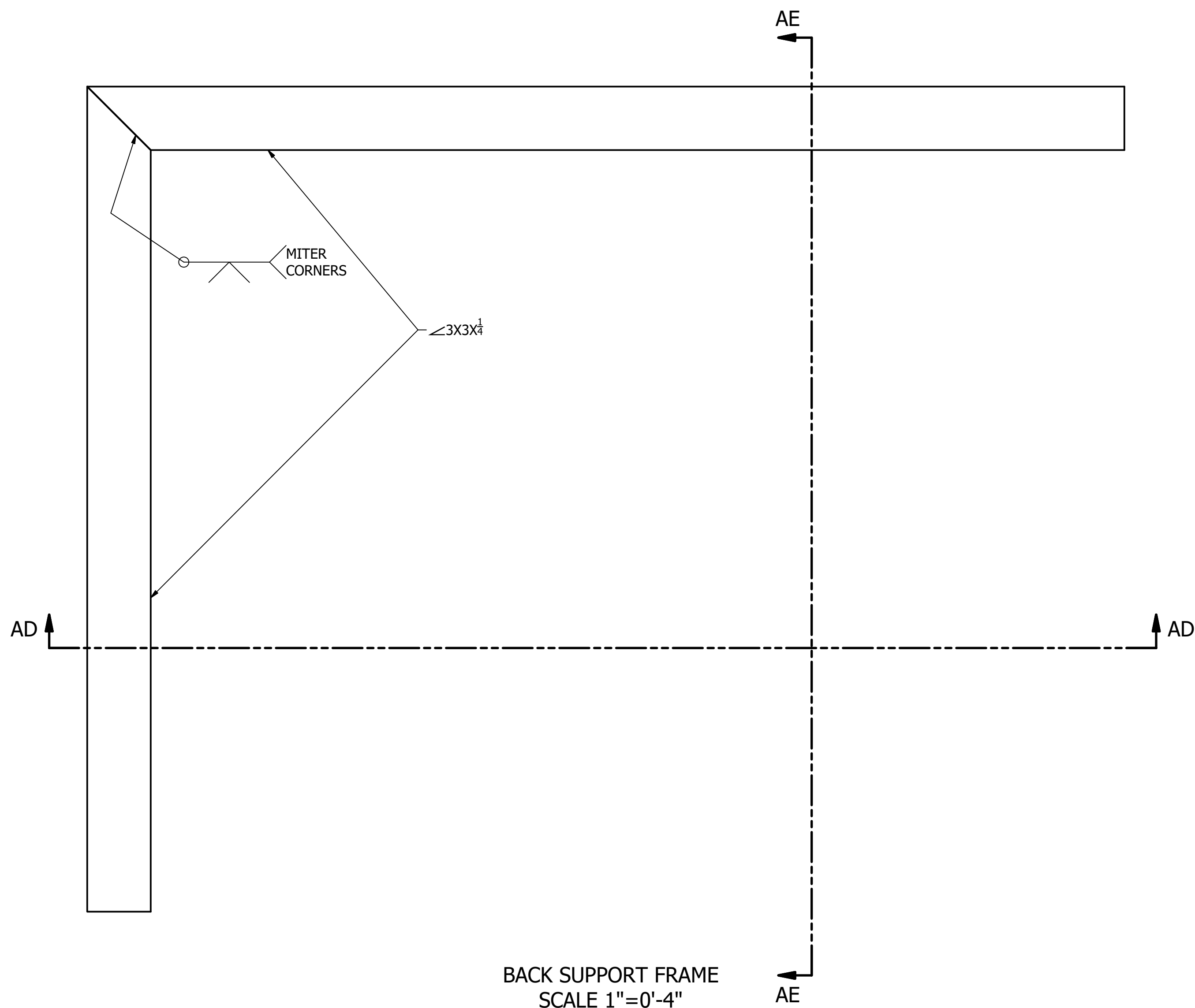

BACK SUPPORT FRAME  
 SCALE 1"=0'-4"

- GRATING SPECIFICATION:**
1. STANDARD-DUTY WELDED, RECTANGULAR BAR
  2. GW-100, 19-W-4 SPACING
  3. GALVANIZED STEEL, HOT-DIPPED
  4. 1" x 3/16" RECTANGULAR BAR
  5. SMOOTH SURFACE
  6. 77% OPEN AREA

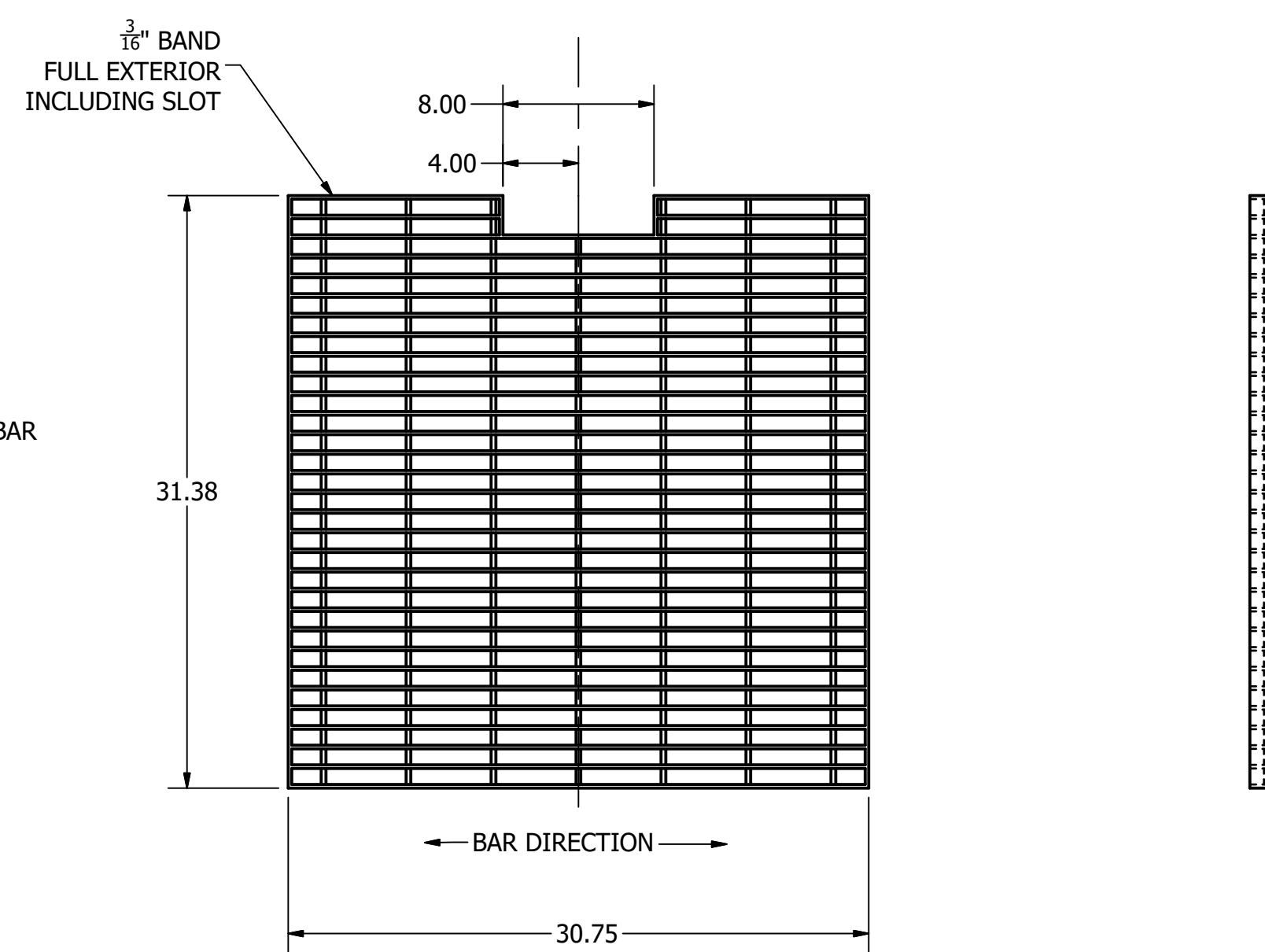

GRATING  
 SCALE 1" = 0'-8"

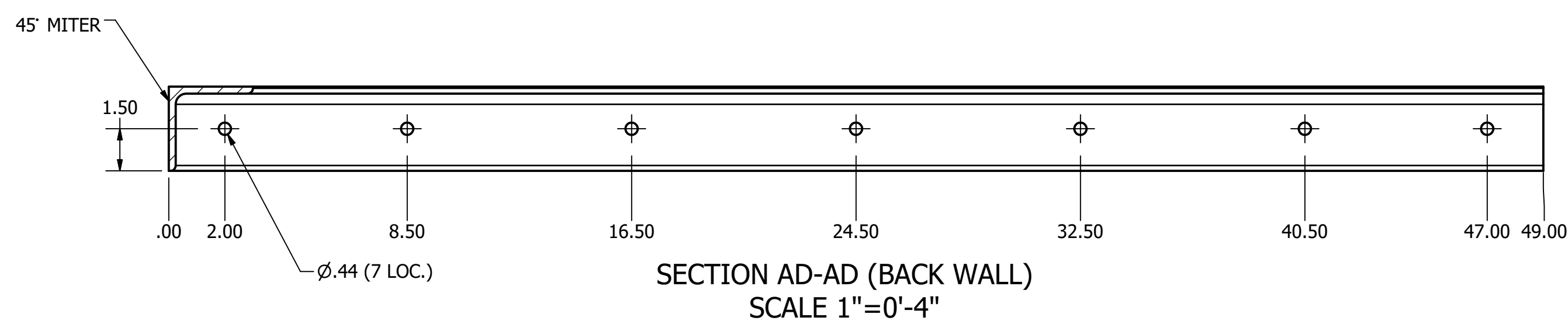

SECTION AD-AD (BACK WALL)  
 SCALE 1"=0'-4"

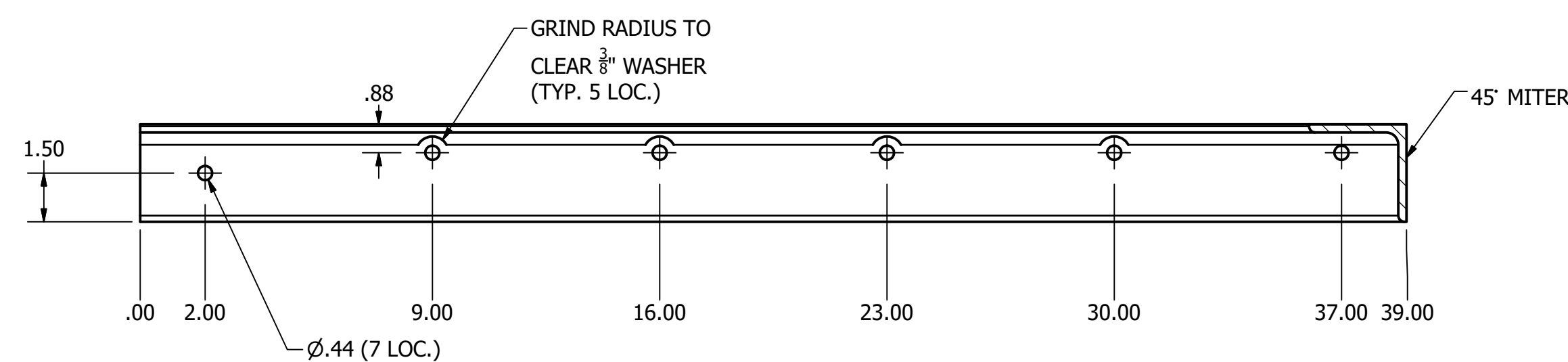

SECTION AE-AE (LEFT DOOR)  
 SCALE 1"=0'-4"

**REVISIONS:**

REV	REVISION ISSUE	DATE
A	ISSUED FOR APPROVAL	04/24/23
B	ISSUED FOR APPROVAL	06/30/23
C	ISSUED FOR APPROVAL	09/11/24
D	ISSUED FOR CONSTRUCTION	09/11/24

**SHEET DESCRIPTION:**

HATCH SUPPORT DETAILS

**SHEET 11 OF 12**

THIS DRAWING IS THE PROPERTY OF INDUSTRIAL TURNAROUND CORPORATION AND IS SUPPLIED FOR USE ONLY FOR AN AUTHORIZED PROJECT. THIS DRAWING CONTAINS CONFIDENTIAL AND PROPRIETARY INFORMATION OF INDUSTRIAL TURNAROUND CORPORATION AND SHALL NOT BE DISCLOSED, USED, COPIED OR REPRODUCED EITHER WHOLLY OR IN PART, EXCEPT IN CONNECTION WITH SUCH USE AND WITH THE PRIOR WRITTEN CONSENT OF INDUSTRIAL TURNAROUND CORPORATION. THIS DRAWING MUST NOT BE USED FOR CONSTRUCTION OR FABRICATION UNTIL SIGNED AS CHECKED AND ISSUED FOR CONSTRUCTION.

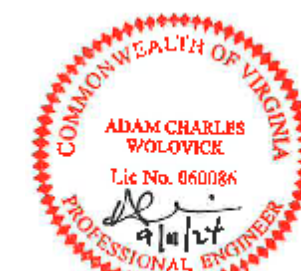

**DRAWING NOTES:**

ALL FABRICATED PARTS TO BE PAINTED SAFETY YELLOW

**REVISIONS:**

REV	REVISION ISSUE	DATE
A	ISSUED FOR APPROVAL	04/24/23
B	ISSUED FOR APPROVAL	06/30/23
C	ISSUED FOR APPROVAL	09/11/24
D	ISSUED FOR CONSTRUCTION	09/11/24

**SHEET DESCRIPTION:**

EXISTING HATCH FALL PROTECTION

**SHEET 12 OF 12**

THIS DRAWING IS THE PROPERTY OF INDUSTRIAL TURNAROUND CORPORATION AND IS SUPPLIED FOR USE ONLY FOR AN AUTHORIZED PROJECT. THIS DRAWING CONTAINS CONFIDENTIAL AND PROPRIETARY INFORMATION OF INDUSTRIAL TURNAROUND CORPORATION AND SHALL NOT BE DISCLOSED, USED, COPIED OR REPRODUCED EITHER WHOLLY OR IN PART, EXCEPT IN CONNECTION WITH SUCH USE AND WITH THE PRIOR WRITTEN CONSENT OF INDUSTRIAL TURNAROUND CORPORATION. THIS DRAWING MUST NOT BE USED FOR CONSTRUCTION OR FABRICATION UNTIL SIGNED AS CHECKED AND ISSUED FOR CONSTRUCTION.

